



**ECS 100**  
**Installation Manual**

---

Access Controls International  
Division of Access Northern Security Inc.  
303 West Main Street  
Freehold, New Jersey 07728

National: 1-888-810-6060  
International: 1-732-462-7236  
Fax: 1-732-462-0511  
E-mail: [ECS@ACIsecurity.com](mailto:ECS@ACIsecurity.com)



**ECS Installation Manual**

Installer \_\_\_\_\_

Date of Installation \_\_\_\_\_

ECS Model \_\_\_\_\_

Serial # \_\_\_\_\_

---

**TABLE OF CONTENTS**

|                   |  |           |
|-------------------|--|-----------|
| <b>Section 1</b>  | <b>General Information.....</b>                      | <b>3</b>  |
| <b>Section 2</b>  | <b>Features and Options.....</b>                     | <b>4</b>  |
| <b>Section 3</b>  | <b>Power Requirements and Wiring Guidelines.....</b> | <b>5</b>  |
|                   | • Power Requirements.....                            | 5         |
|                   | • Wiring Guidelines.....                             | 6         |
|                   | • Grounding.....                                     | 9         |
| <b>Section 4</b>  | <b>Location and Mounting Guidelines.....</b>         | <b>10</b> |
| <b>Section 5</b>  | <b>Installation.....</b>                             | <b>11</b> |
|                   | • Block Diagram Layout.....                          | 11        |
|                   | • Installation Configurations .....                  | 12        |
|                   | • Installing Reader Technology.....                  | 18        |
|                   | • ComKey Reader.....                                 | 18        |
|                   | • Wiegand Output Readers.....                        | 20        |
|                   | • RF Receivers.....                                  | 21        |
| <b>Section 6</b>  | <b>Final Connections.....</b>                        | <b>22</b> |
| <b>Section 7</b>  | <b>System References.....</b>                        | <b>23</b> |
|                   | • Multi Technology.....                              | 23        |
|                   | • ComKey Reader Slimline Plate .....                 | 24        |
|                   | • Printer Module.....                                | 25        |
|                   | • Request To Exit.....                               | 26        |
|                   | • ECS Power Wiring.....                              | 27        |
|                   | • ECS Wiegand-to-Dallas Format Converter.....        | 28        |
|                   | • Control Component Logic.....                       | 29        |
| <b>Section 8</b>  | <b>Troubleshooting Symptom Guide.....</b>            | <b>31</b> |
| <b>Section 9</b>  | <b>Specifications.....</b>                           | <b>32</b> |
| <b>Section 10</b> | <b>Dimensions.....</b>                               | <b>33</b> |

## **Section 1 – GENERAL INFORMATION**

The *ECS-100* is a single door, stand alone access control system which features on-site programming using a built-in keypad and LED display.

The system communicates using Dallas 16 bit output format and can also communicate with all reader technologies that use Wiegand 26 Bit output format using the ECS data format converter module. Most reader technologies can be used, including ComKeys (button technology), Proximity Cards and Tags, RF Remote Controls, Keypads, Swipe Cards, RFID Tags and Biometrics.

The Model 100 requires 12 VDC power supplied by a plug-in DC transformer or a power supply/charger if a back-up battery is utilized. Output control is accomplished with one form C relay contact configured for latching or momentary activation.

The *ECS-100* system kit includes the following standard equipment:

- An *ECS-100* Controller Board mounted in a heavy duty steel enclosure; Also mounted in the enclosure is a 12 volt DC power supply/charger with a 4 ampere hour back up battery and , if required, a data format converter;
- One (1) credential reader based on your technology choice (ComKey Reader, Proximity Reader, RF Receiver, etc.);
- One (1) Request-To-Exit push button station;
- Twenty Five (25) Credentials (ComKeys, Proximity Cards, Proximity Tags or RF Remote Controls, based on your technology selection);
- Fifty (50) feet of either Six (6) conductor flat cable (ComKey) or Four (4) conductor cable (Wiegand) (for connection of the reader to the controller board);
- Two (2) RJ-12 connectors, one (1) crimping tool, mounting screws, installation manual and user manual.

You may also request optional equipment, including:

- Additional credential reader;
- Additional credentials (the *ECS-100* supports up to 500 users);
- Parallel port printer interface module to permit real time event tracking;
- Power Supply/Charger with 7 ampere hour battery back up;
- Request-To-Exit Motion Detector or Exit Release Push Bar;
- Magnetic Door Locks or Electric Strikes

## **Section 2 – FEATURES AND OPTIONS**

The *ECS-100* controls up to 500 users.

Access is controlled by communication between a site reader and a site controller, upon presentation of a valid access credential.

Reader options include: ComKey, Proximity, RF Receiver, Keypad, Swipe, RFID and Biometric.

The *ECS-100* communicates through a link between the controller board and the reader device. When a valid credential is presented at the reader, it is identified by the reader and validated by the controller, which will activate a dry contact relay. The controller then sends a GREEN feedback LED signal to the reader. (An invalid credential will result in a RED signal)

A normally closed circuit connection is provided on the controller board for a Request to Exit or Emergency Lock Release input.

Real time event tracking and database user reports can be produced. A printer output connection is included on the *ECS-100* controller and when used in conjunction with an optional printer interface module will allow connection to any parallel port printer.

Initial USER CREDENTIAL ENROLLMENT and other controller programming can be performed either prior to control cabinet installation and final cable connections (the *ECS-100* has non-volatile memory) or at the control cabinet location after installation is complete, depending on administrator preference or convenience. For ComKey credentials, the on-board ComKey reader is available for this purpose. If credentials other than ComKeys are being used, a separate enrollment programmer will be needed, which plugs into the controller via an RJ12 connection. As an alternative to a separate programmer when Proximity or Keypad technologies are used, a special Proximity Reader or Keypad can be installed in the control cabinet sharing the Data 0 and Data 1 terminal connections on the ECS Wiegand to Dallas converters to allow convenient user enrollments, additions and deletions. Refer to the *ECS-100* User Manual for additional details.

## Section 3 – POWER REQUIREMENTS AND WIRING GUIDELINES

### Power Requirements

The ECS-100 operates with 12 VDC @ 300mA. It is supplied with either a 12 VDC 600mA (or higher) plug-in type converter or a power supply/charger, AC transformer and either a 4 ampere/hour or 7 ampere/hour battery, if standby power is to be used.

The ECS-100 system was shipped with its own power supply designed to power the controller board and any optional equipment. If you are using a locking device not supplied with the ECS system, check manufacturer’s specifications for load current required. Verify that it does not exceed the power supply’s output. If it does, you must use a separate power supply for the device.

#### Maximum power supply current output:

|   |         |         |
|---|---------|---------|
| PS-50 12vdc plug-in type converter..... | 600mA   | @ 12vdc |
| PS-51 power supply/charger .....        | 1.2 amp | @ 12vdc |
| PS-52 power supply/charger .....        | 2.5 amp | @ 12vdc |
| PS-53 power supply/charger .....        | 4.0 amp | @ 12vdc |

If you are using reader technologies in conjunction with your ECS-100 that require constant power, they must draw power from the ECS supply.

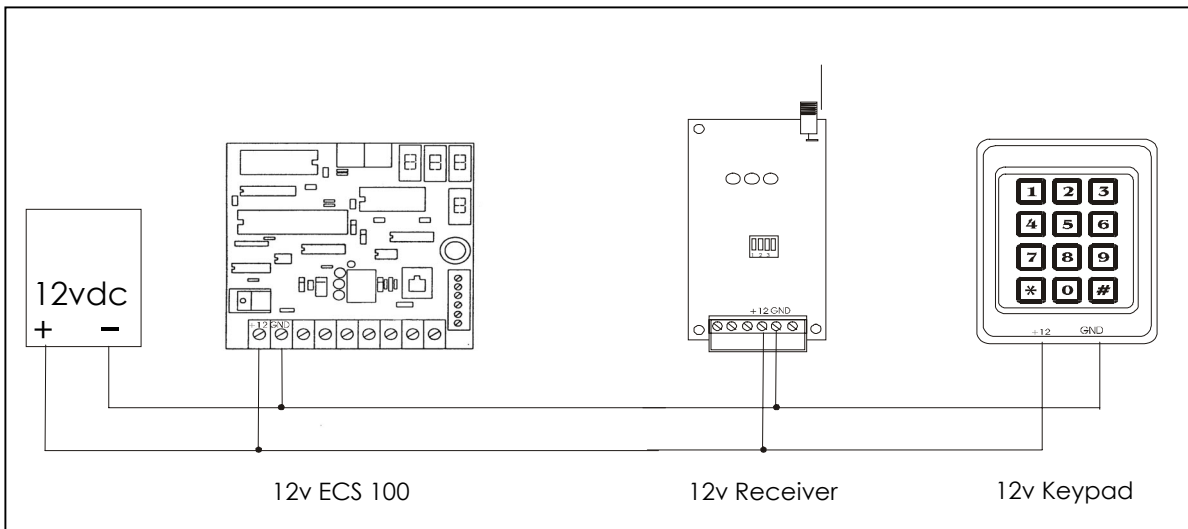

Figure 1-Power connections

## Wiring Guidelines

The wiring of the *ECS-100* system is an extremely important and integral part of the entire system. The cables should be run after the control cabinet location is determined and it is very important that proper wire is used to connect the technologies to the system.

For all installations:

- Avoid running data lines parallel to or in close proximity to high voltage lines or other sources of EMI such as motors, transformers, fluorescent lighting, etc., these are likely to interfere with data transfer affecting the ability of the system to function properly.
- It is recommended that data lines do not exceed 500 feet. Beyond this point the data transmission may degrade or weaken.
- Do not include locking device wires along side of the data cable unless the locking device wires can be separately shielded.
- Request-To-Exit devices can be wired using the same cable as the reader provided two additional conductors are available.
- Low capacitance cable is **strongly** recommended.

**COMKEY** Readers are connected using 26/6 flat wire with RJ12 plugs on each end that attach directly into both the Reader and the ECS-100 Controller Board. If conduit is used for the wire run, the 26/6 wire may not withstand the stress of being pulled through the conduit. In this case the use of 22 to 24 AWG, 6 to 8 conductor, unshielded type CM data cable is recommended, with splices to 26/6 flat wire at each end for RJ12 connection. Suggested methods of splicing can be solder, crimp or terminal blocks.

Special connector modules may be obtained for joining the two cable types and to reduce installation time. These can be 'punch-down' type connectors such as AMP#H4-93830241 or equivalent. Surface mount 'quick-connect' type jacks such as Leviton #41036-IDA or equivalent may also be used. These jacks allow easy termination of multi-conductor cable, enabling 26/6 flat wire to be plugged in directly with RJ12 connectors (see Figures 2b and 2c).

**WIEGAND** Readers are connected using 18 or 22 AWG, 4 to 6 conductor, type CM or CL2 shielded data cable. A recommended cable is Genesis #1216 or #2216 for vertical riser installations (or equivalent cable from other manufacturers). The data cable is wired directly from the reader to a data format converter located in the control cabinet. The converter output is transferred to the Controller Board using either plug-in RJ12 connectors on 26/6 flat cable or by running a single wire from the '16 Bit Output' terminal on the converter to the 'Aux' terminal on the Controller Board. (see Figure 17 on Page 24)

**Connecting 26/6 flat wire to RJ12 plugs**

26/6 Flat Wire is used for connection between ComKey Readers and the ECS 100 Controller or as one method of connecting the Wiegand Format Converter to the ECS 100 Controller Board.

To construct the cable flat wire, RJ12 connectors and a crimp tool are needed, all of which are included with the kit.

The cable is standard telephone installation wire and the connection into the jacks must be reversed for communication to work. As a reference to ensure proper alignment, note that the cable has a smooth side and a raised seam side. If you install both RJ12 connectors release tab up, on the same side of the cable, you will insure proper alignment and functioning.

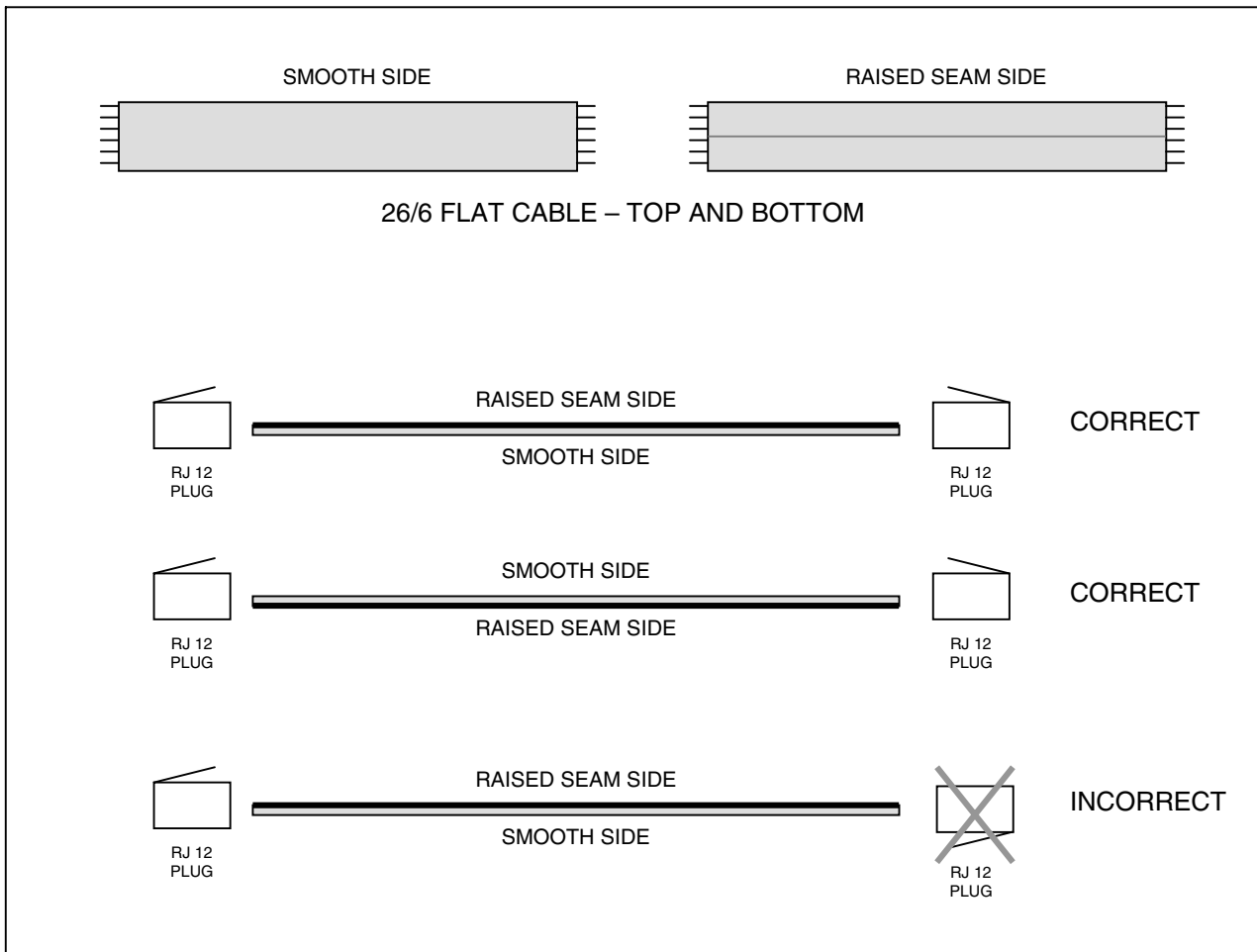

**Figure 2a** – RJ12 Plug Connection to 26/6 Flat Cable

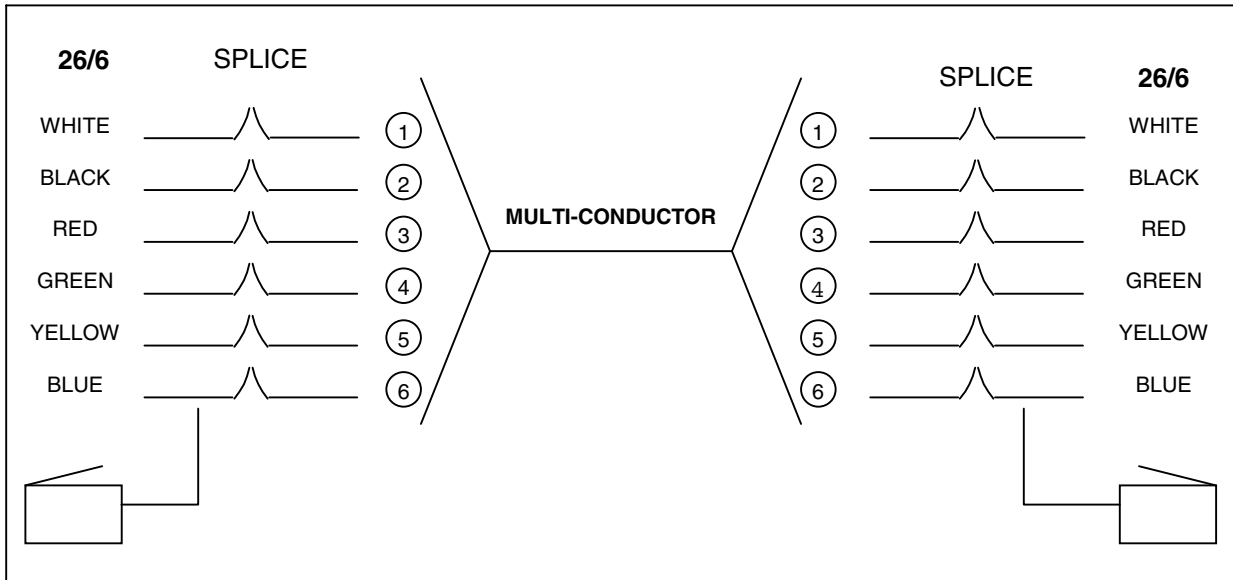

**Figure 2b** – Multi-Conductor Wire Splicing

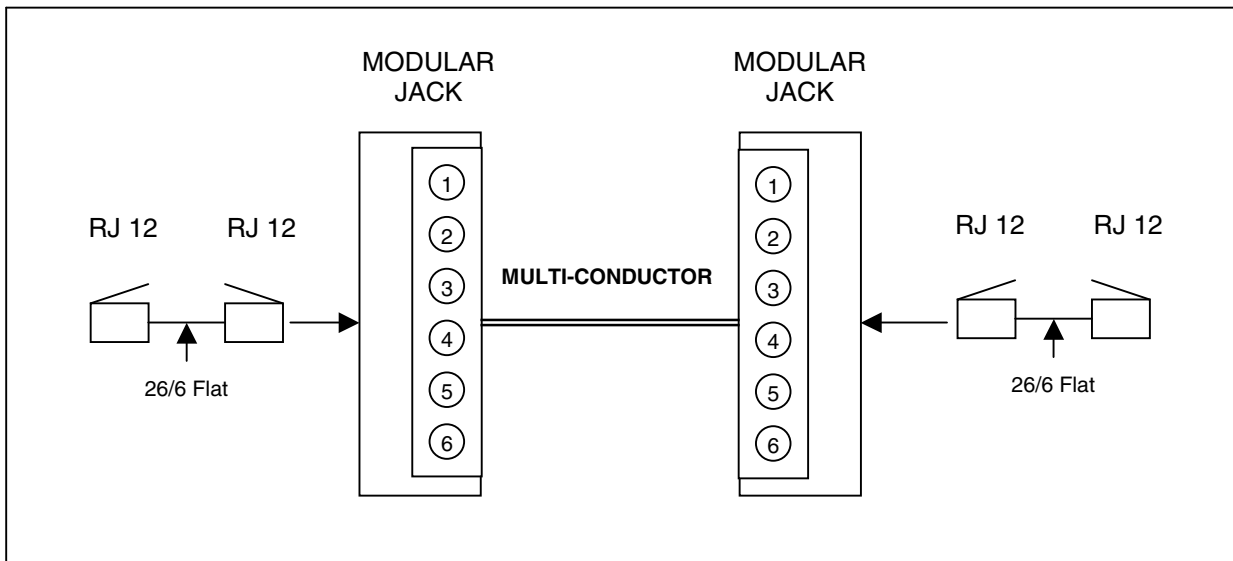

**Figure 2c** – Multi-Conductor Modular Splicing

### Grounding

The unit must be properly grounded to protect it from the effects of static and lightning. Surge suppressors are recommended on power lines.

Attach a separate 12 AWG insulated wire to GND terminal and attach the other end of this wire to earth ground. This can be a properly grounded metal conduit, cold water pipe, or a grounding rod driven at least 10 feet into the soil. Keep the ground wire as short as possible.

If you are using a separate surge suppressor, it must also be grounded to function properly.

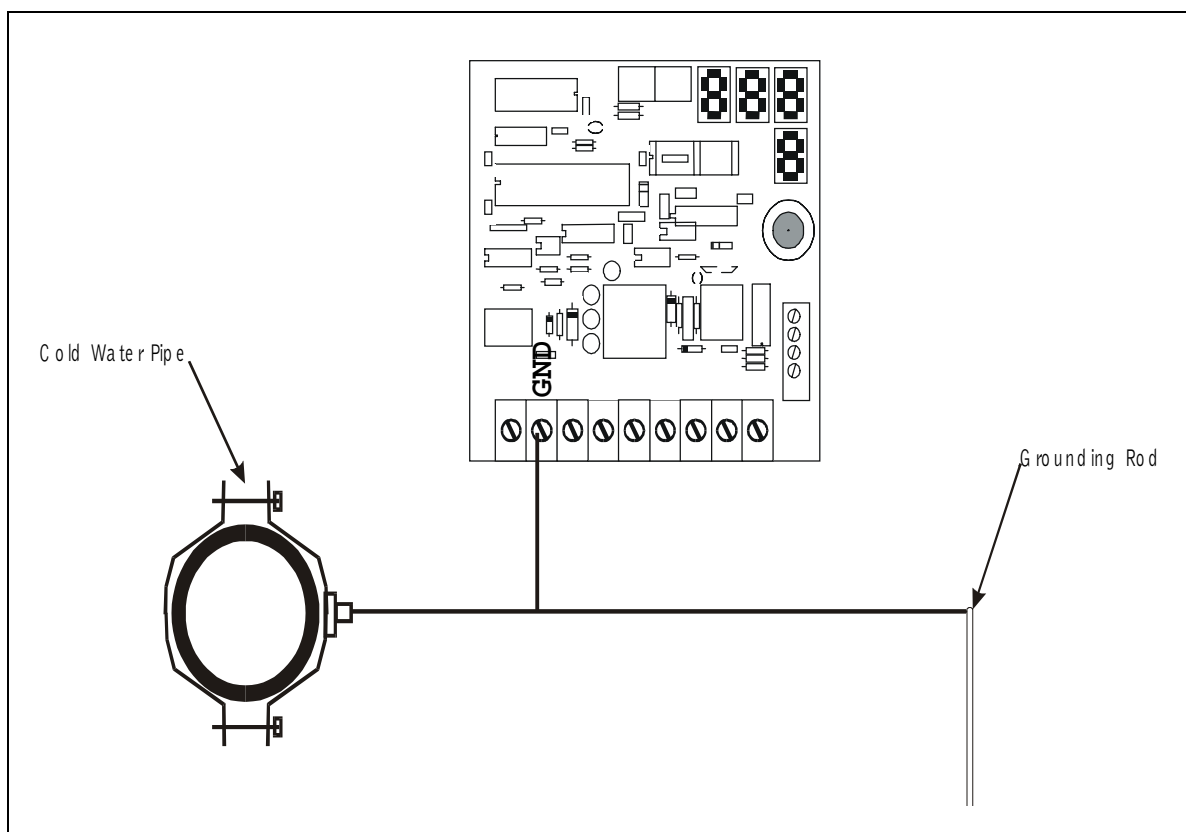
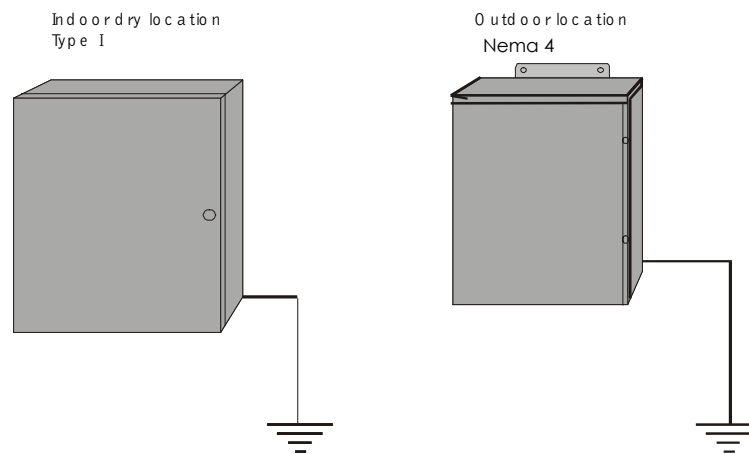

**Figure 3-**Grounding the controller board

## Section 4 – LOCATION AND MOUNTING GUIDELINES

The *ECS-100* unit is housed in a control cabinet designed to be surface mounted to any wall. You must be certain to properly ground the cabinet to a good earth ground.

If an outdoor location is required for your installation, the unit must be housed in a weatherproof enclosure rated NEMA 4, for proper protection against moisture. **Temperature and humidity extremes may require additional steps to prevent unreliable equipment operation. If there are any concerns regarding the location environment, check with the manufacturer.**



**Figure 4 - Enclosure examples**

### Mounting the Enclosure

Choose a location where the control cabinet will not be exposed to moisture or leaks. Secure the cabinet to the wall surface with proper fasteners, then bring any conduit to the cabinet through knockouts provided. **Do not install any conduit through the top of the cabinet.**

The *ECS-100* is a keypad programmable system, therefore, installation height should be considered for accessibility. It is recommended that the control board terminal strip be no higher than 5 feet from the floor and no further than 500 feet from your reader device location.

Be sure that power is available nearby for the transformer to be plugged-in. If power is not available nearby, you must have power brought to the location. **Do not use extension lines to power the unit.**

Once the Control Cabinet location is determined, cables can be run in accordance with the Wiring Guidelines outlined in Section 3 (page 6).

**Section 5 – INSTALLATION**

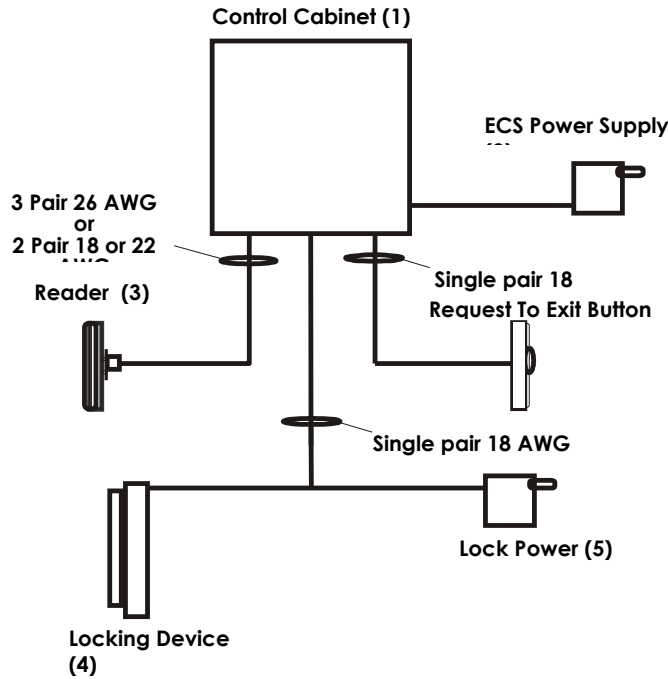

**Figure 5 - Installation Block Diagram**

| Block Diagram Description |                        |  |
|---------------------------|------------------------|--|
| 1                         | Control Cabinet        | Houses the <i>ECS-100</i> Controller Board, Lock Control Relay and Wire Termination                    |
| 2                         | ECS Power Supply       | Plug-In type, 12 Volt DC   |
| 3                         | Reader                 | ComKey Reader technology connected with 26/6 flat line cord or Wiegand Reader with 22/4 type CM cable. |
| 4                         | Locking Device         | Any type of fail safe or fail secure lock that is controlled by the <i>ECS-100</i> output relay        |
| 5                         | Locking Device Power   | A separate voltage source to supply a common to lock and device load through the relay                 |
| 6                         | Request-To-Exit Device | If the locking device requires a relay control to provide egress, a normally closed switch is used     |

## Installation Configurations

### Standard Installation Configurations

The ECS-100 standard installation utilizes a Normally Closed Momentary Exit Device and can be configured with either Magnetic Locks (Figures 6 / 6a) or Electric Strikes (Figures 7 / 7a). Fail Safe or Fail Secure operation is determined by the type of locking device and not the connections to the controller. The Standard installation is the simplest and most common for the majority of installations

More comprehensive alternative installation configurations, involving the locking device and the controller board are depicted on subsequent pages.

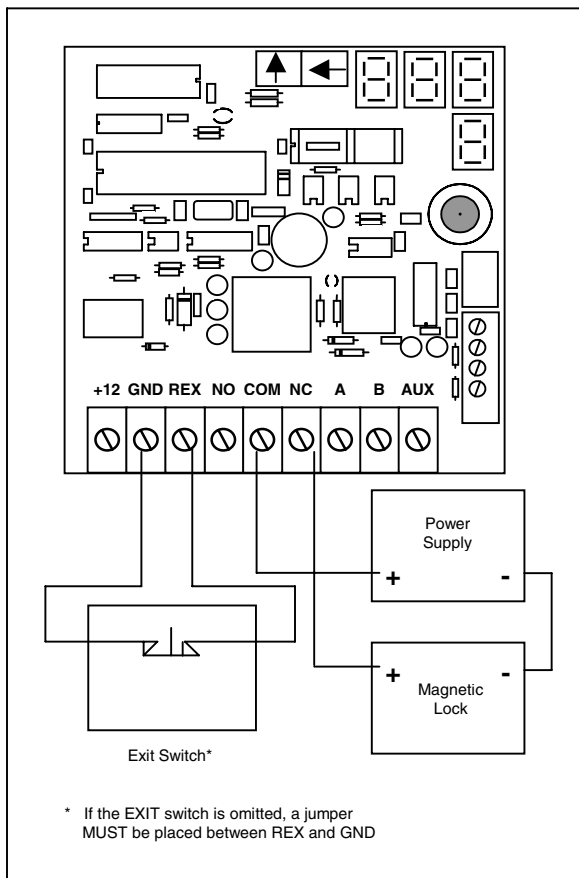

**Figure 6** – Standard Installation -  
Magnetic Lock -  
Using Separate Lock Power

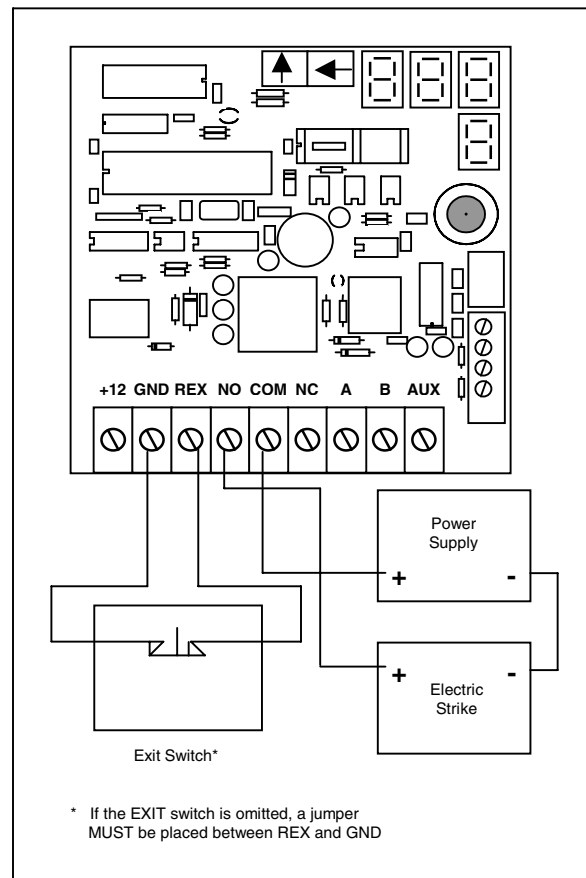

**Figure 7** – Standard Installation -  
Electric Strike -  
Using Separate Lock Power

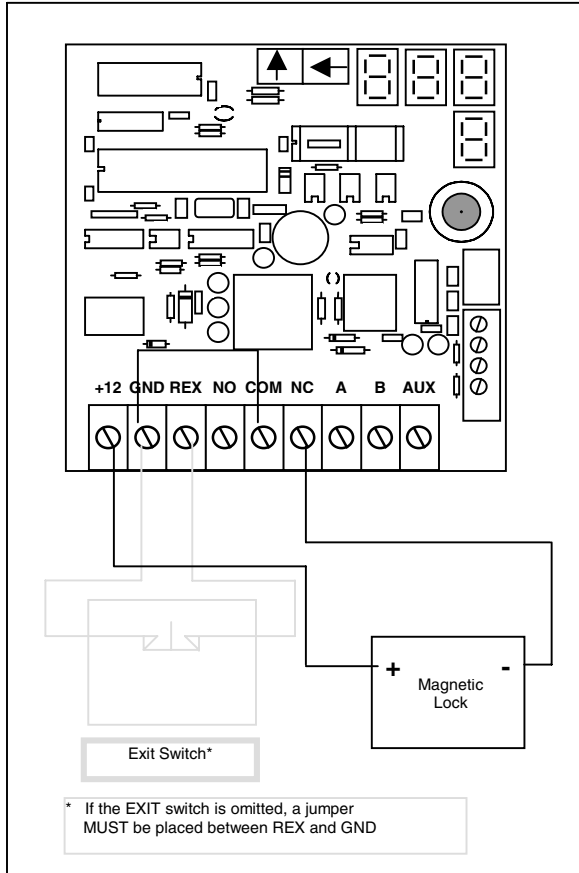

**Figure 6a** – Standard Installation -  
Magnetic Lock –  
Drawing Power Directly From  
The Controller Board

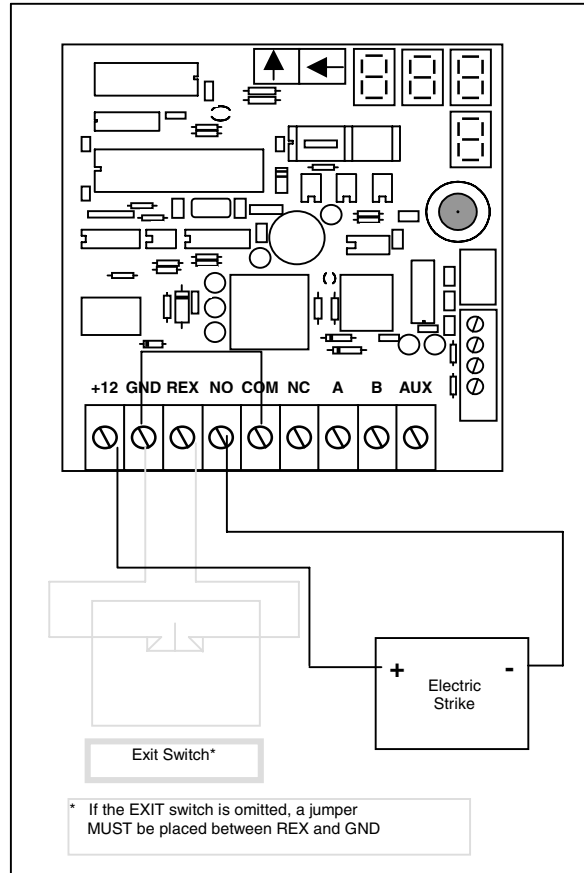

**Figure 7a** – Standard Installation -  
Electric Strike -  
Drawing Power Directly  
From The Controller Board

**IMPORTANT NOTE:** When drawing power directly from the Controller Board be sure that the power supply being used provides sufficient current (amperage) to support all devices being powered.

### Alternative Fail Safe/Fail Secure Configurations

#### FAIL SAFE Lock with FAIL SAFE Installation

This installation ensures that the **doors will unlock** in the event of a power loss to the lock or if the relay fails. **Make sure the door energize option is set to '0' (off)**. By setting the option to OFF, the controller will de-energize the relay on a valid read or an override condition. This type of installation should be used when maximum system safety is desired. Figure 8 shows the wiring for a **fail safe** installation. This method uses a double pole – single throw EXIT switch. When the EXIT switch is pushed, an override is sent to the controller *and* the power supply to the lock is interrupted. This guarantees that the lock will unlock even if the controller fails (during a possible fire situation) because power is interrupted to the lock by the switch.

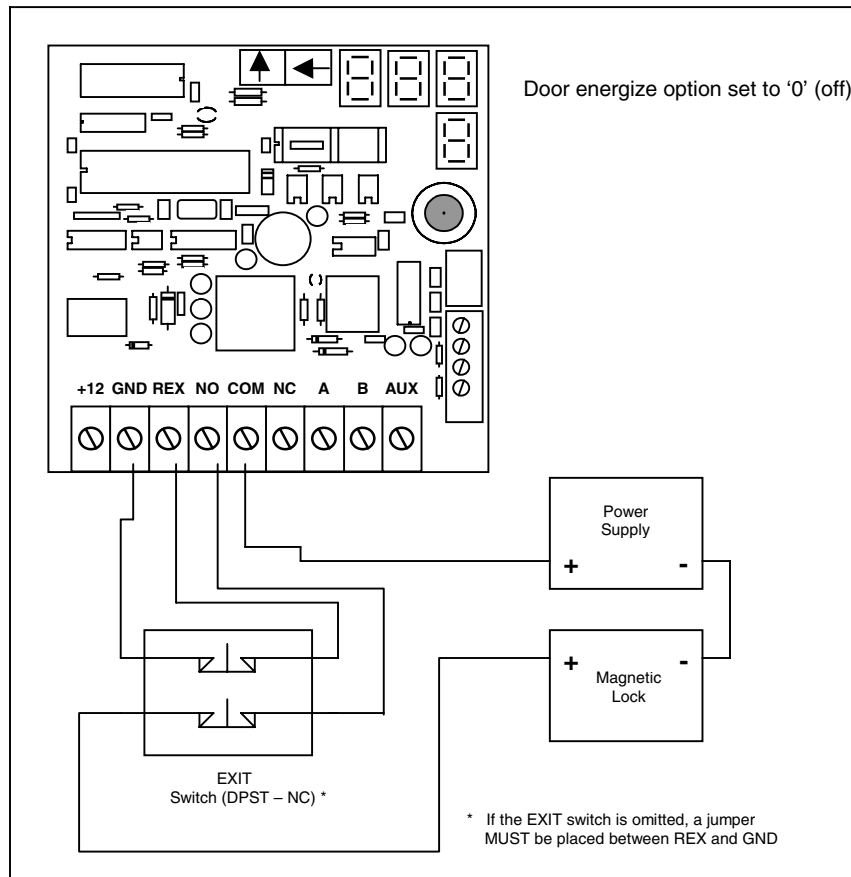

**Figure 8** -Fail Safe Installation with Fail Safe Lock  
[Requires power to lock]

## FAIL SAFE Lock with FAIL SECURE Installation

This installation ensures that the doors will UNLOCK in the event of a power loss to the lock and will LOCK if the relay fails. **Make sure the door energize option is set to '1' (on).** By setting the option to ON, the controller will energize the relay on a valid read or an override condition thereby unlocking the door. This type of installation should be used when it is desired to LOCK the door during any kind of controller failure. Figure 9 shows the wiring for a **fail secure** installation. This method uses a double pole – single throw EXIT switch. When the EXIT switch is pushed, an override is sent to the controller and the power supply to the lock is interrupted. This guarantees that the lock will unlock even if the controller fails (during a possible fire situation) because power is interrupted to the lock.

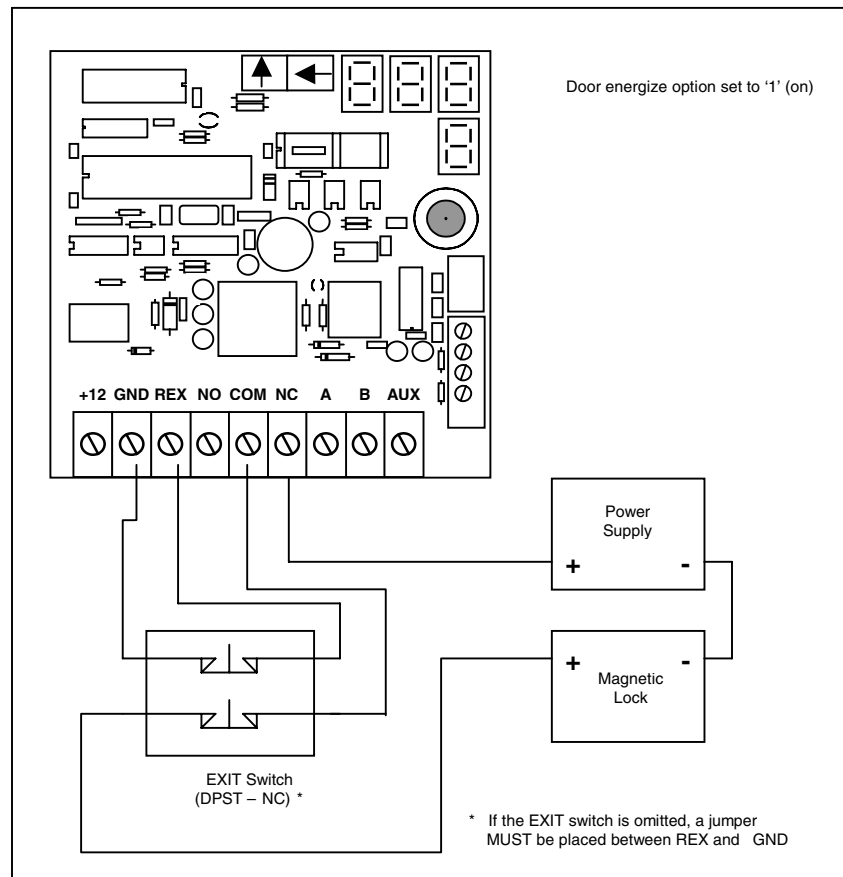

**Figure 9 - Fail Secure Installation with Fail Safe Lock**  
[Requires power to lock]

FAIL SECURE Lock with FAIL SAFE Installation

This installation ensures that the doors will LOCK in the event of a power loss to the lock and will UNLOCK if the relay fails. **Make sure the door energize option is set to '0' (off)**. By setting the option to OFF, the controller will de-energize the relay on a valid read or an override condition. This type of installation should be used when maximum system safety is desired. Figure 10 shows the wiring for a **fail safe** installation. This method uses a double pole – double throw EXIT switch. When the EXIT switch is pushed, an override is sent to the controller and power is applied to the lock. This guarantees that the lock will unlock even if the controller fails (during a possible fire situation) because power is applied directly to the lock by the switch.

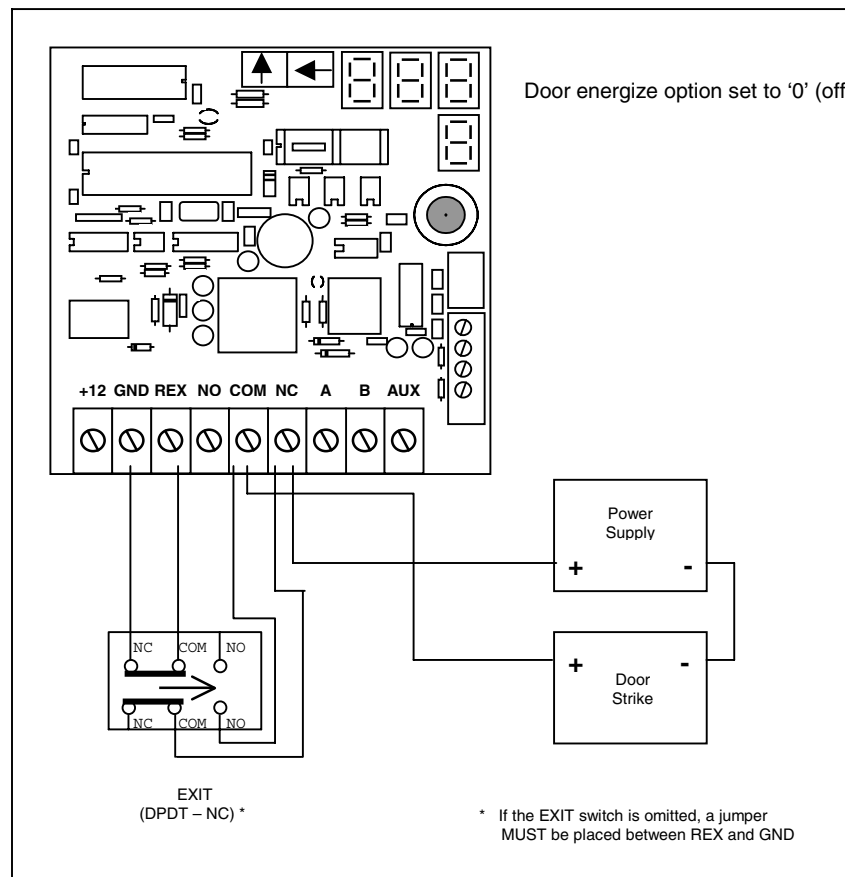

**Figure 10 - Fail Safe Installation with Fail Secure Lock**  
[Requires power to Unlock]

FAIL SECURE Lock with FAIL SECURE Installation

This installation ensures that the doors will LOCK in the event of a power loss to the lock or if the relay fails. **Make sure the door energize option is set to '1' (on).** By setting the option to ON, the controller will energize the relay on a valid read or an override condition. This type of installation should be used when it is desired to LOCK the door during any kind of controller failure. Figure 11 shows the wiring for a **fail secure** installation. The preferred method uses a double pole – double throw EXIT switch. When the EXIT switch is pushed, an override is sent to the controller and power is interrupted to the lock. This ensures that the lock will remain locked even if the controller fails (during a possible fire situation) because power to the lock is interrupted.

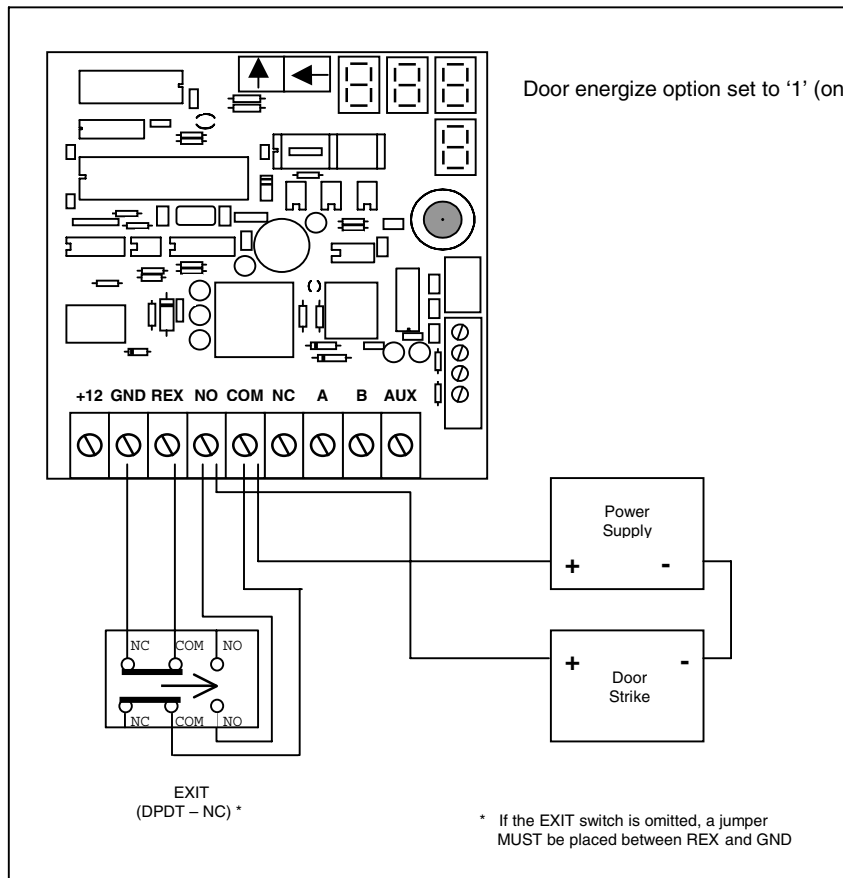

**Figure 11 - Fail Secure Installation with Fail Secure Lock**  
[Requires power to unlock]

## Installing Reader Technology

### ComKey Reader

Slimline ComKey reader plates are designed to fit most door frames. The plate is surface mounted with the RJ12 connector block recessed behind it. Full size ComKey reader plates are designed to be either surface mounted on a wall or recess mounted using an electrical box.

If a request-to-exit push button is being used, it should also be installed at this point.

Typical push button height is 38" to 42".

Readers using other technology vary in their mounting requirements. In all cases, however, mounting heights and location should be considered for the end user.

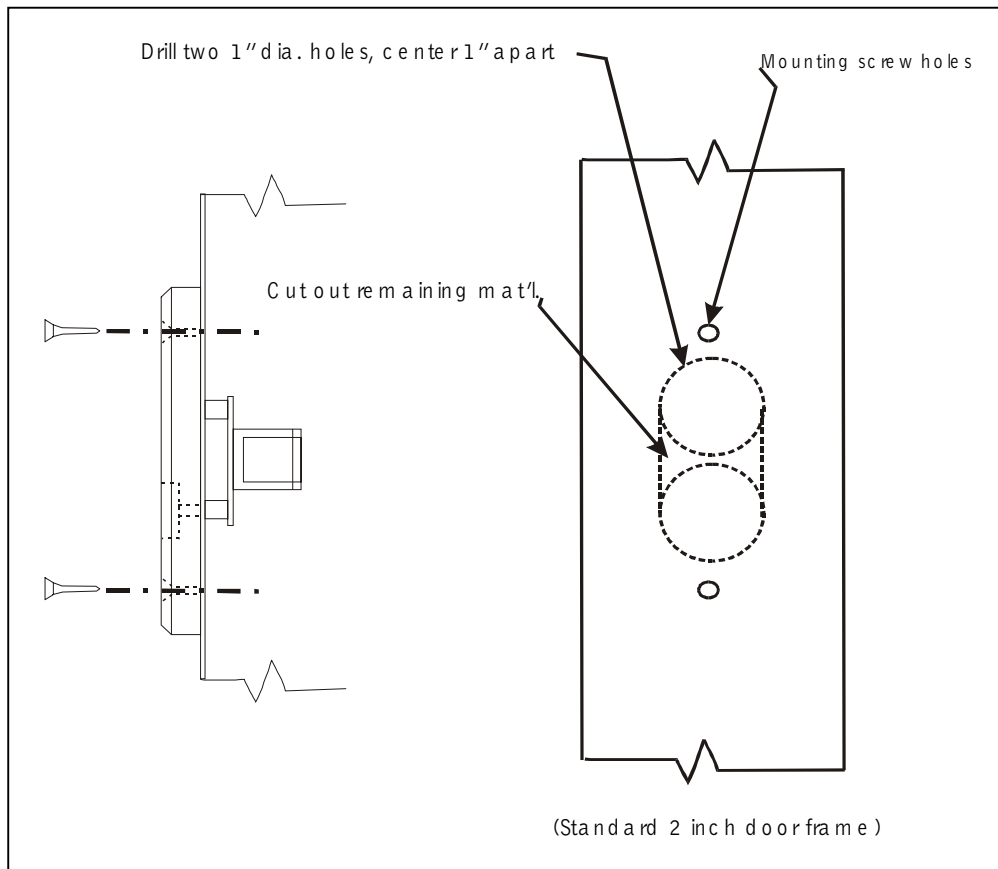

**Figure 12 - ComKey Reader Installation**

The reader faceplate is interfaced to the ECS controller board by directly connecting the 26/6 flat cable to location J1, with RJ12 connectors as shown. If an additional reader is being connected to the controller, use a six conductor modular Y adapter. Make sure that the RJ12 connectors are properly oriented on the flat wire as shown in section 3 (Wiring Guidelines).

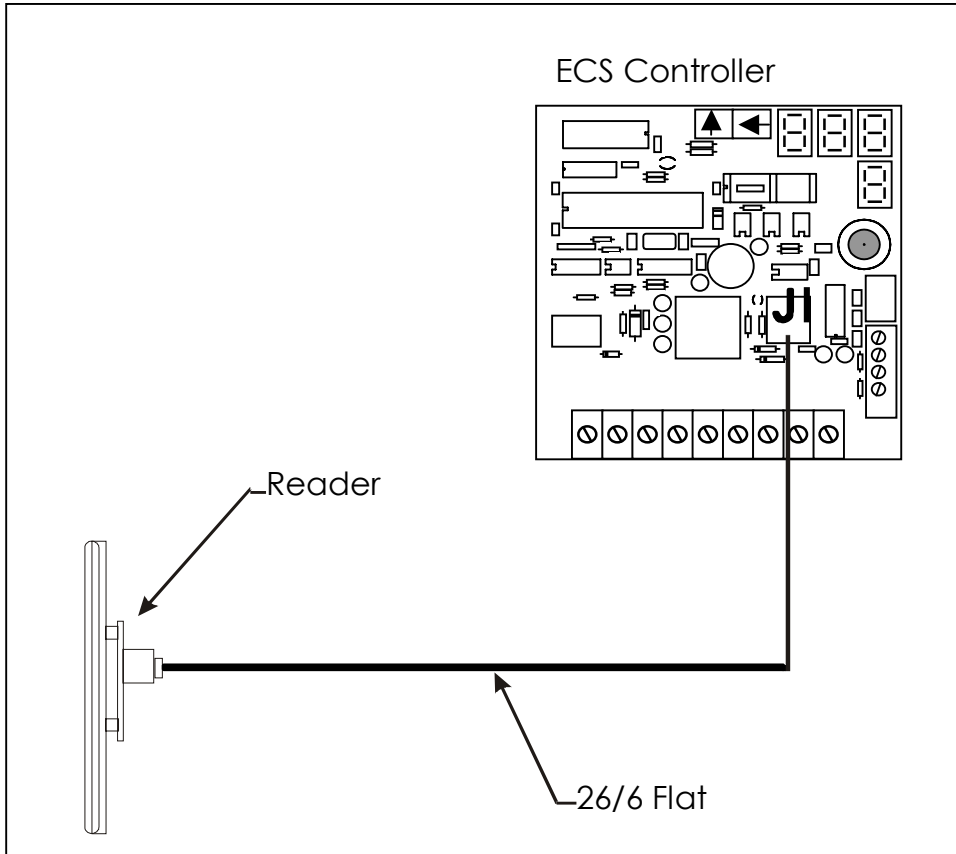
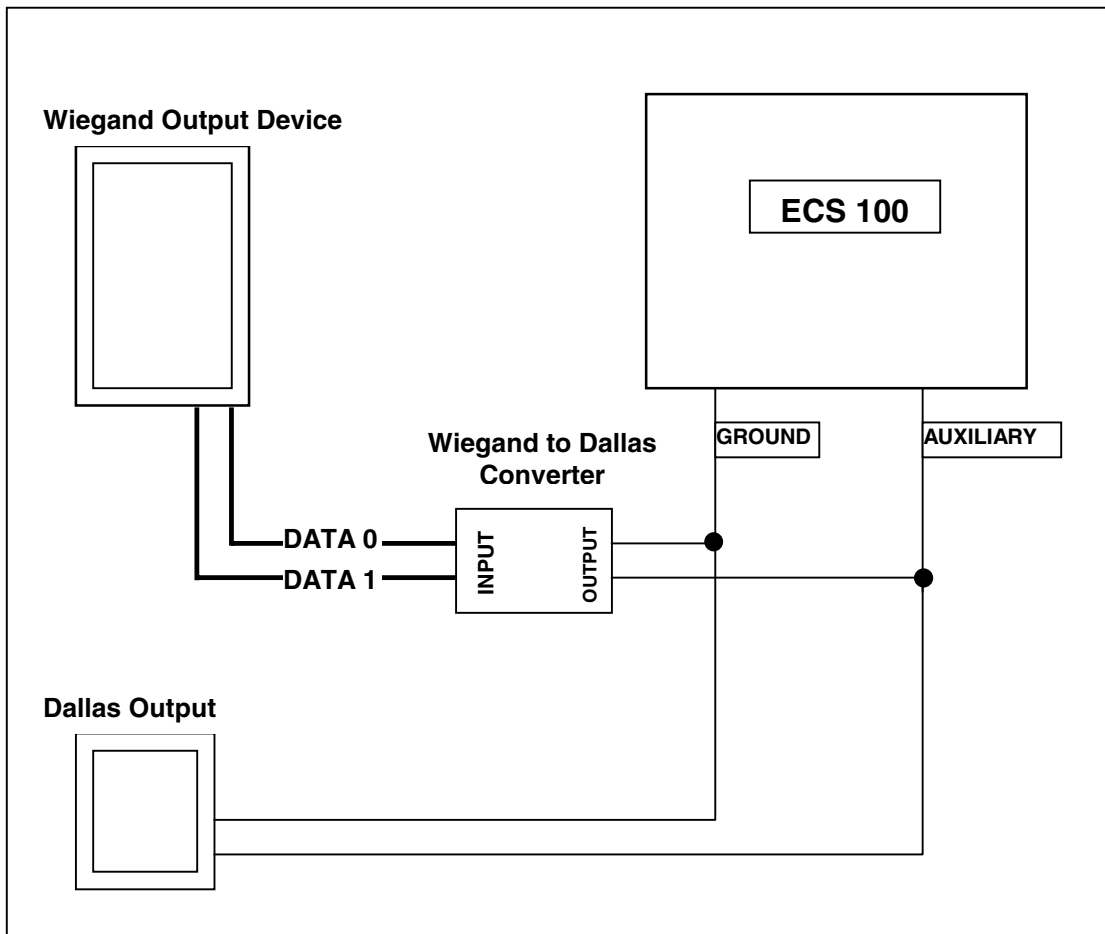

**Figure 13 - ComKey Reader to Controller Connection**

**Wiegand Output Reader Devices**

The ECS system will interface with communicating reader devices, which use either the Wiegand or Dallas output, format.

Wiegand output format must be converted to Dallas format through use of an *ECS* format converter. On some systems this converter will be pre-installed along with the controller board inside the cabinet. If it is not installed or if Wiegand output technology is added at a later date, it is important to properly connect power and data between these devices. (Refer also to Figure 17 on Page 24).



**Figure 14 - Wiegand Output Reader to Controller Connection**

**RF Receivers**

If an RF receiver is being used as the reader device, determine the location using the following guidelines:

|                          |   |
|--------------------------|---|
| <p>Less than 20 feet</p> | <p>If the receiver is in close proximity to the location of the control cabinet <u>and</u> the locking device, it may be mounted in the control cabinet. Provide proper antenna mounting with coaxial cable barrel connector and locknut</p>  |
| <p>Over 20 feet</p>      | <p>If the receiver will be mounted remotely from the <i>ECS-100</i>, it must be installed in a separate housing and grounded. Avoid locating the antenna close to metal objects and power lines. For best performance, it is always better to move the receiver closer to the transmitter location, not the antenna. Unit should be mounted at the highest possible point for best reception.</p> |

**Table 1**

Provide a proper earth ground from the earth ground solder lug to a ground point within 12 feet of the unit. Refer to wiring diagram, in the final connections, to properly connect the receiver to the cable. If the receiver and enclosure are installed outdoors, be sure to use a NEMA 4 or 4X type enclosure.

The receiver board is mounted into the enclosure on stand-offs. Note that one corner hole of the board is tinned for grounding purposes. Antenna connectors are F59 type.

## **Section 6 – Final Connections**

After all reader technology devices have been installed at their locations, verify that each has been properly connected to its cable.

For devices that require a constant power source of 12 VDC, connect red wire [+12V] and black wire [-Neg ground].

Readers with Wiegand output, 26 bit data stream, use Data 0 and Data 1 connections to the format converter to interface with the ECS controller. These must be correctly oriented with Data 0 and Data 1 on the Wiegand format converter. Refer to ECS Wiegand Converter Reference in Section 7.

If standard ComKey readers are used, verify that the RJ 12 connectors are correctly installed, referring to Section 3.

If the ECS system is being used to control equipment with automated movement such as overhead doors, gates, or lifts, bring up power to the ECS first, then power up the equipment controlled by it. This will prevent sudden movement caused by the output on power-up. After the system is powered and running, the controller is ready to be programmed.

Note that the *ECS-100* uses non-volatile memory, and can be programmed on the bench prior to installing.

## **Section 7 – System References**

### **Multi-Technology**

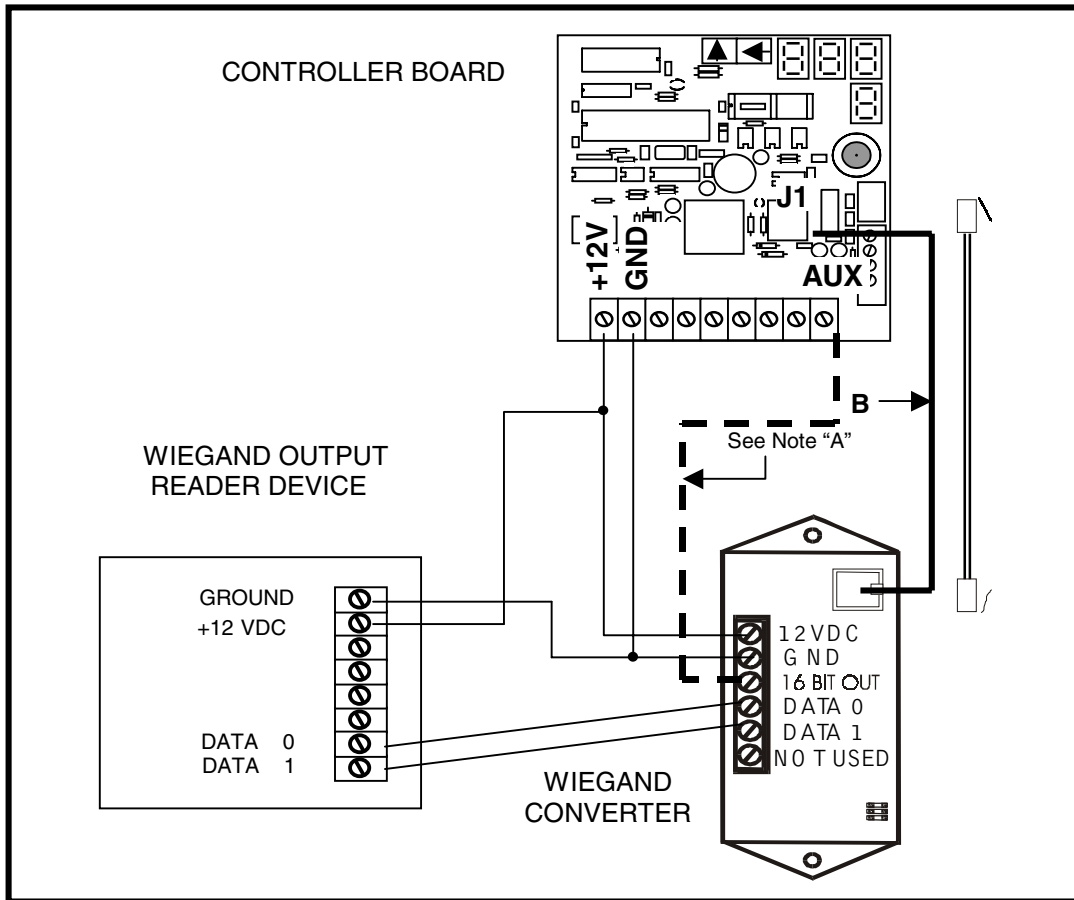
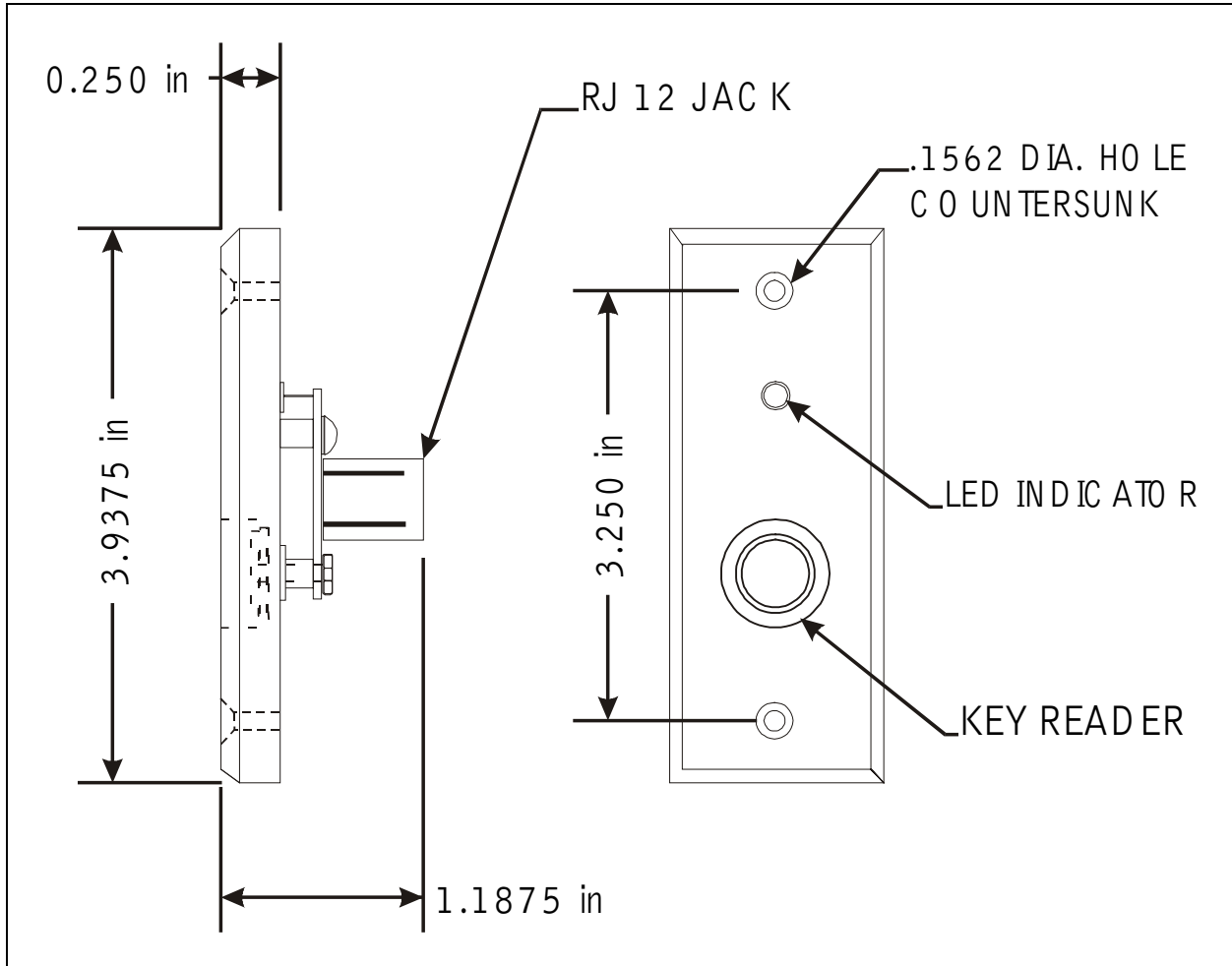

**Figure 15 - ECS Wiegand-to-Dallas Converter Connections**

- Both the Wiegand output reader and the *ECS* Wiegand-to-Dallas converter use the *ECS*-100 control board power (12 VDC).
- Observe Data 0 and Data 1 connections between device and converter.
- The *ECS* Wiegand-to-Dallas converter can either be directly wired or use 26/6 flatline cord and RJ12 connectors to communicate with the control board.

**NOTE A:** As an alternative to the RJ12 connection or if a Wiegand output reader is installed in addition to a ComKey reader, both controlling the same output relay, run a wire from **Terminal 3** (16 Bit Output) on the converter to the **AUX** terminal on ECS board and omit wire “B”. The ComKey reader (if dual technology is being used) can be plugged directly into RJ12 jack at pos J1.

**Com-Key Reader Faceplate**



**Figure 16 - Stainless Steel Slim Line ComKey Reader**

- Slim line (shown) or full size ComKey reader plate connected to RJ12 jack on *ECS-100* control board.

**ECS Printer Module**

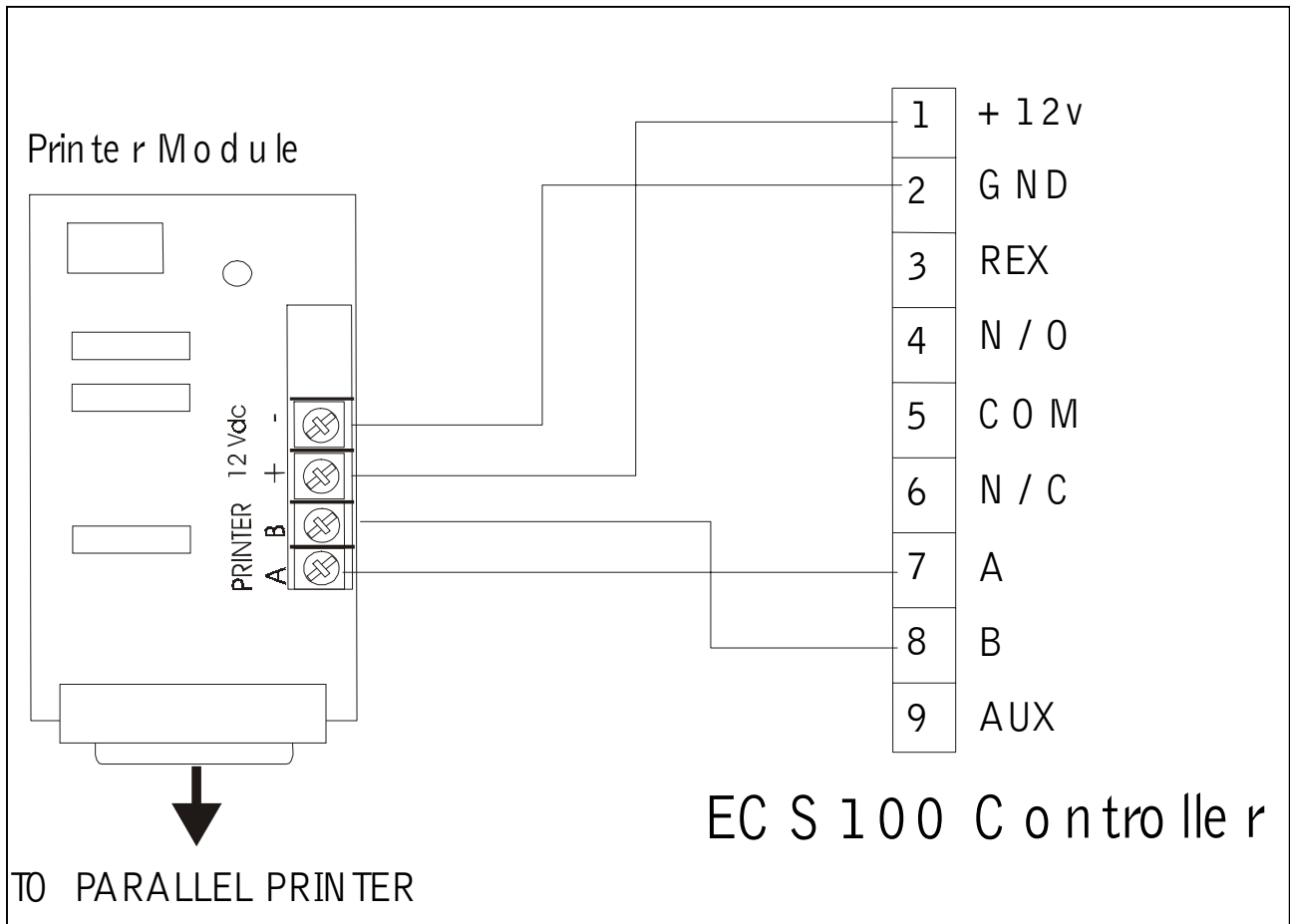

**Figure 17 - ECS Printer Module connection**

- Optional printer module requires 12 VDC power.
- Connect Terminal A and B (TB 1) on module to control board printer output A and B.
- DB25 port for output to parallel printer.

ECS Request to Exit Input

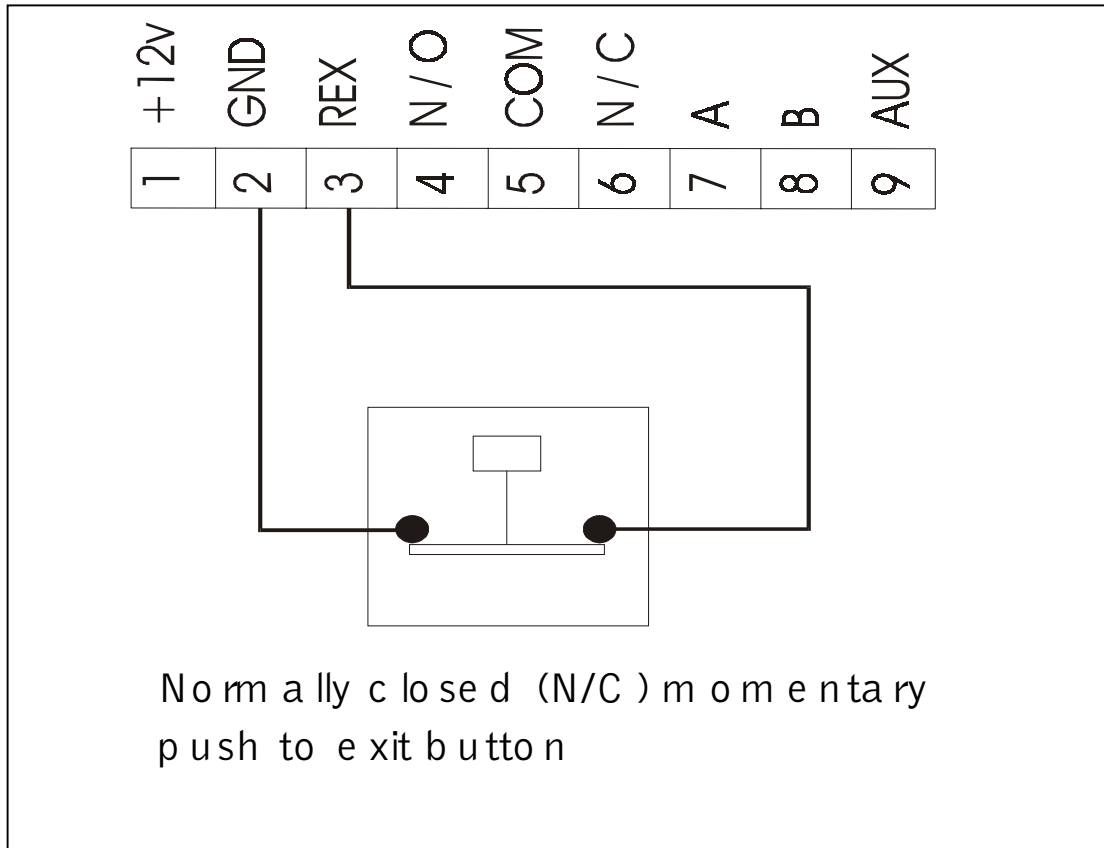

**Figure 18** - Request To Exit connection

- A request to exit button must be a momentary, normally closed switch connected to Terminals 2 and 3.
- An “open” across 2 and 3 will not allow controller to recognize input from readers.
- If no input is connected to Terminals 2 and 3, a jumper must be installed.
- May also be connected to a latching output from equipment such as fire alarms.

ECS 100 Power Wiring

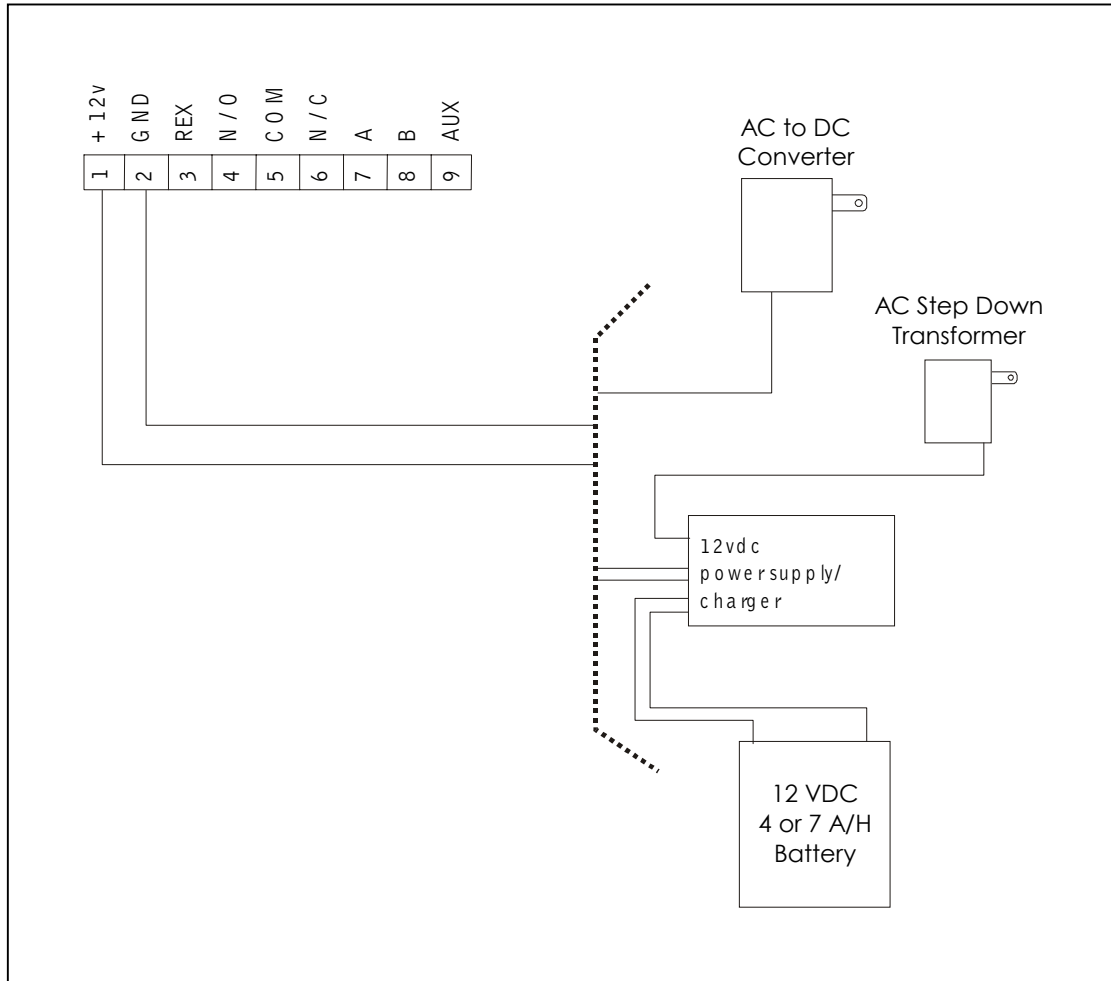
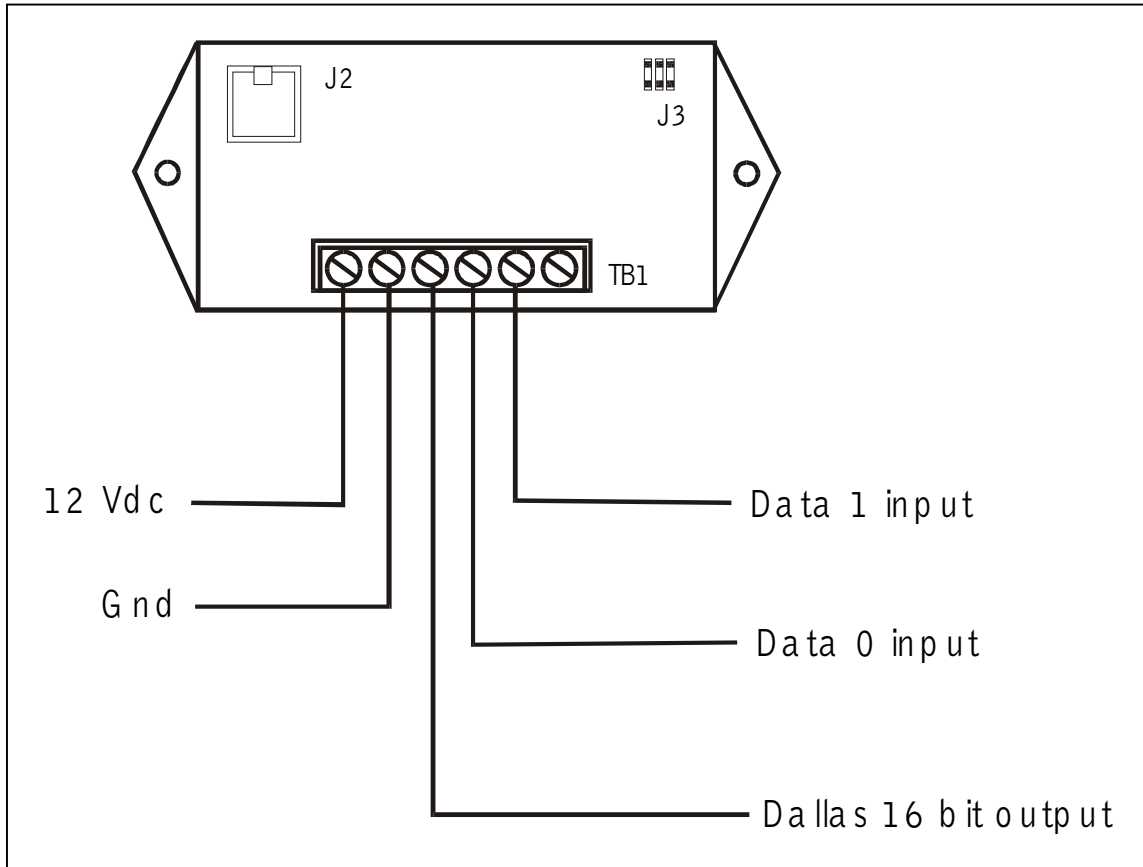

Figure 19 - Available power sources and wiring

- 12 VDC power connected to Terminal 1 and 2 on *ECS-100* control board.
- Power supplied by DC plug-in type transformer or optional standby battery backup with power supply charger.
- Electric strikes or magnetic locks must be powered by a separate transformer.

**ECS Wiegand-to-Dallas Converter**



**Figure 20 - ECS Wiegand-to-Dallas Converter Terminals**

- Powered by 12 VDC from control board.
- Standard Wiegand output from reader to Data 0 and Data 1 terminals.
- Converted format output at RJ12 Jack J2.

**Control Component Logic**

[Controller Board Diagram relating to the following table can be found on page 29]

| Component                          | Function   |
|------------------------------------|--|
| <b>TB 1</b><br>Terminal Strip      | For connecting power, pushbutton, relay output, printer output, AUX data input   |
| <b>TB 2</b><br>Terminal Block      | For connecting composite reader output to LED indicators and backlight   |
| <b>J1</b><br>RJ Connector Jack     | Type RJ jack for connecting 26/6 flat cable using RJ12 connectors  |
| <b>D5</b><br>LED                   | Light emitting diode to indicate when output relay has energized   |
| <b>D8</b><br>LED                   | Light emitting diode to indicate when 12 VDC is present at Terminals 1 and 2   |
| <b>SW1</b><br>Push Buttons         | For programming navigation while in program mode, otherwise no input   |
| <b>U11</b><br>LED Display          | Flashing display to indicate normal operation<br>Steady display to indicate program modes                                      |
| <b>U9, U10, U13</b><br>LED Display | 3 position display of memory locations and programming data  |
| Board Mounted<br><b>Key Reader</b> | Com key reader, board mounted for initializing program mode and introducing keys, will also read a valid key for relay output. |

**Table 2**

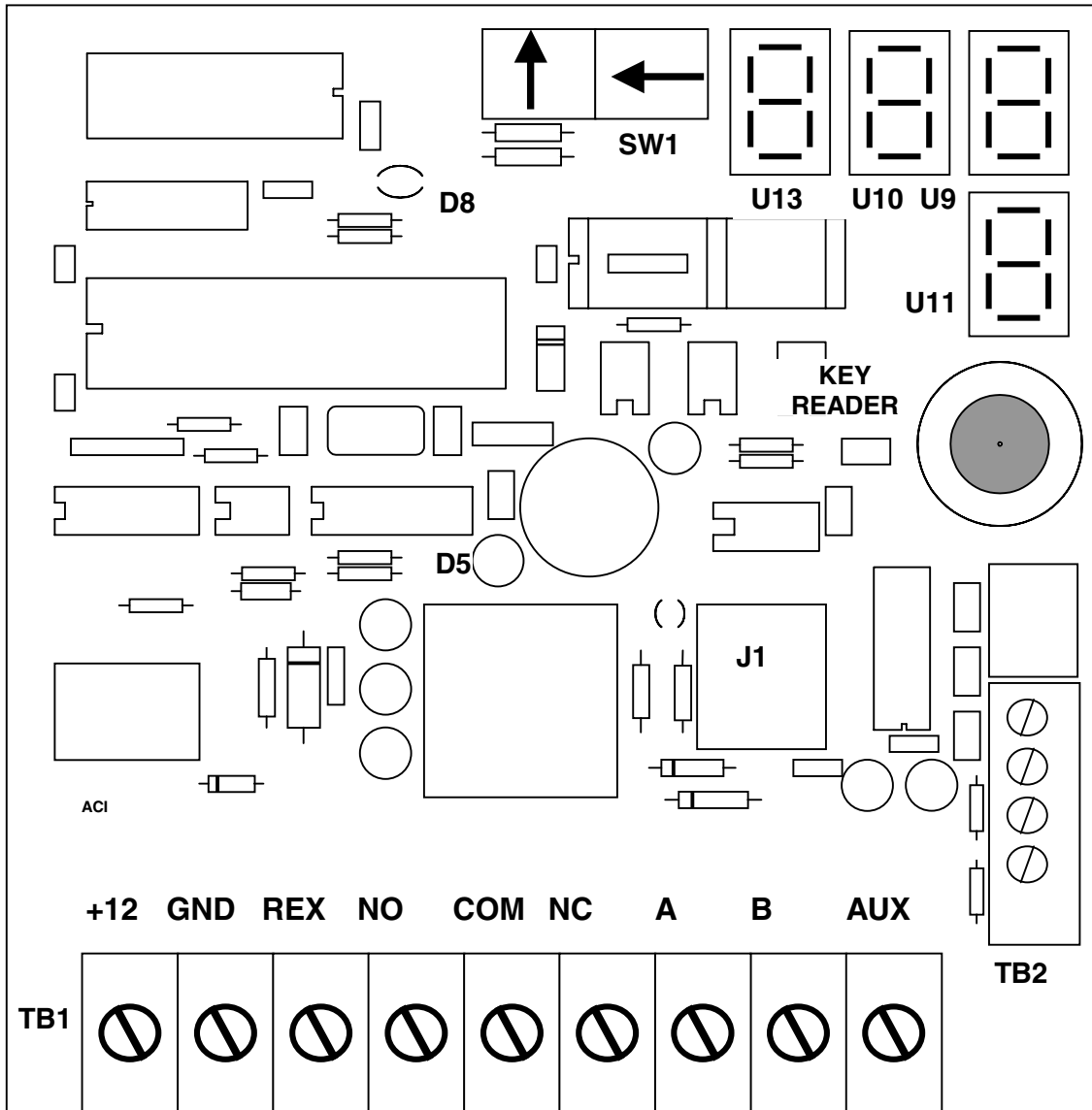

**Figure 21 – ECS Controller Board with Component Logic**

## **Section 8 - Troubleshooting Symptom Guide**

### **A. No Output from Relay**

1. Check the relay energize LED D5. If it is lit, the relay is energized. Check the programming configuration for latching or momentary (mode 1 or 0).
2. Place a jumper across Terminal 2 and 3 (GND and REX) on the control board. If relay LED D5 goes out, there is an open in the request to exit circuit.
3. Check for improperly connected reader. Disconnect any key readers from control board. If relay activates, the reader or wiring is at fault.

### **B. No Key Read Indicated At Reader Plate**

1. Connect a voltmeter across the key reader POS + to center conductor neg – to reader plate, and verify that there is 5 VDC present. If voltage is not present, check all connectors and splices in the reader cable.
2. Disconnect power to control board, wait 15 seconds and reconnect. If system now operates, be sure the load on the relay contact has not exceeded its rated specification. High contact load may require the use of surge/noise suppressors.
3. Substitute the reader with a new one, the LED may be at fault.
4. Verify that RJ12 connectors between reader and board, or Wiegand converter and board, are correctly oriented on cable and no short or open exists between each end.

### **C. Request to Exit Button Will Not Activate Relay.**

1. Check configuration for door relay energize state.
2. Make sure there is no jumper across Terminals 2 and 3 (GND and REX).
3. Check for 12 VDC across Terminals 1 and 2 (+12V and GND).
4. Disconnect the input from Terminals 2 and 3, connect a continuity tester across these wires. Circuit should be closed, and should open when button is pressed.
5. Disconnect reader cable at each end and verify that there are no shorted connections in the six conductor cable.

**Section 9 – Specifications**

|                                 |                 |
|---------------------------------|-----------------|
| ECS 25.....                     | 100 mA max      |
| ECS 100 .....                   | 300 mA max      |
| ECS 200 .....                   | 300 mA max      |
| ECS 400 and Turbo .....         | 500 mA max      |
| ECS Printer Module .....        | < 50 mA         |
| ECS Data Format Converter ..... | < 50 mA         |
| Temperature range .....         | 32 °F to 158 °F |
| Relative humidity.....          | 85 % or less    |

**Section 10 Dimensions**

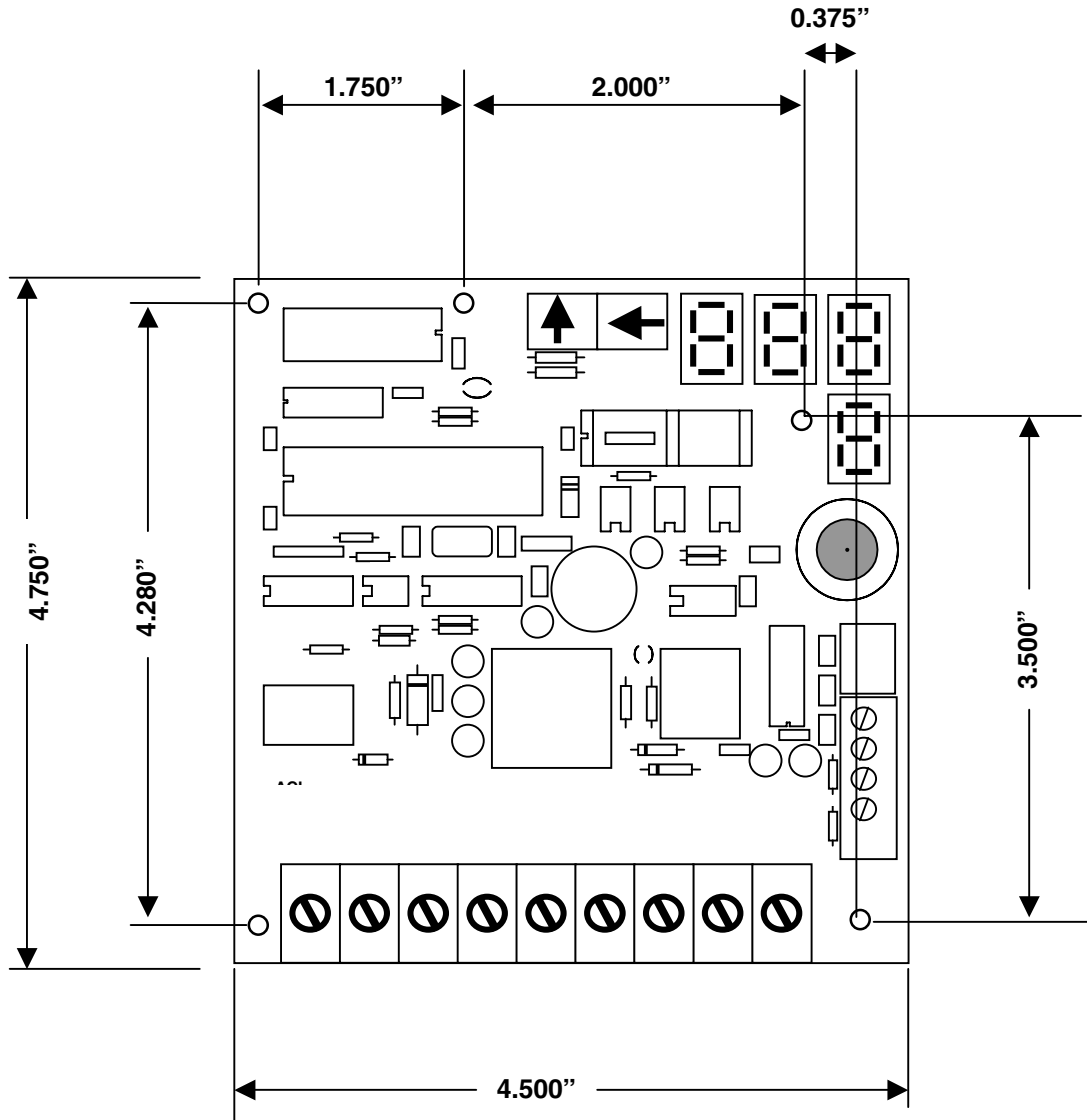

**Figure 22** – ECS-100 Controller Board Dimensions

- Mounting hole locations -center to center
- Controller board dimensions –corner to corner

NOTES

NOTES