



ECS 25

Installation Manual

© 2001-2004

Access Controls International
Division of Access Northern Security Inc.
303 West Main Street
Freehold, New Jersey 07728

National: 1-888-810-6060
International: 1-732-462-7236
Fax: 1-732-462-0511
E-mail: ECS@ACIsecurity.com

ECS Installation Manual

Installer _____

Date of Installation _____

ECS Model _____

Serial # _____

TABLE OF CONTENTS

Section 1	General Information.....	3
Section 2	Features and Options.....	4
Section 3	Power Requirements and Wiring Guidelines.....	5
	• Power Requirements.....	5
	• Wiring Guidelines.....	6
	• Grounding.....	9
Section 4	Location and Mounting Guidelines.....	10
Section 5	Installation.....	11
	• Block Diagram Layout.....	11
	• Installation Configurations	12
	• Installing A ComKey Reader	13
Section 6	Final Connections.....	15
Section 7	System References.....	16
	• ComKey Reader Slimline Plate	16
	• Request To Exit.....	17
	• ECS Power Wiring.....	18
	• Control Component Logic.....	19
Section 8	Troubleshooting Symptom Guide.....	20
Section 9	Specifications.....	21
Section 10	Dimensions.....	22

Section 1 – GENERAL INFORMATION

The *ECS 25* is a single door, stand alone access control system which features on-site programming using a connected ComKey Reader with a tri-color LED.

The system communicates via Dallas 16 bit output format using ComKey Credentials(button technology).

The Model 25 requires 12 VDC power supplied by a plug-in DC transformer or a power supply/charger if a back-up battery is utilized. Output control is accomplished with one form C relay contact configured for latching or momentary activation.

The *ECS-25* system kit includes the following standard equipment:

- An *ECS-25* Controller Board mounted in a heavy duty steel enclosure; Also mounted in the enclosure is a 12 volt DC power supply/charger with a 4 ampere hour back up battery;
- One (1) ComKey Reader;
- One (1) Request-To-Exit push button station;
- Ten (10) Credentials and Two(2) Administrator ComKeys;
- Fifty (50) feet of Six (6) conductor flat cable hook up wire (for connection of the reader to the controller board);
- Two (2) RJ-12 connectors, one (1) crimping tool, mounting screws, installation manual and user manual.

You may also request optional equipment, including:

- Additional credential reader (if free egress is not desired);
- Additional credentials (the *ECS-25* supports up to 25 users);
- Request-To-Exit Motion Detector or Exit Release Push Bar;
- Magnetic Door Locks or Electric Strikes

Section 2 – FEATURES AND OPTIONS

The *ECS-25* controls up to 25 users.

Access is controlled by communication between a site reader and a site controller, upon presentation of a valid access credential.

The *ECS-25* communicates through a link between the controller board and the ComKey Reader. When a valid credential is presented at the reader, it is validated by the controller, which will activate a dry contact relay. The controller then sends a GREEN feedback LED signal to the reader. (An invalid credential will result in a RED signal)

A normally closed circuit connection is provided on the controller board for a Request to Exit or Emergency Lock Release input.

Initial USER CREDENTIAL ENROLLMENT and other controller programming can be performed either prior to control cabinet installation and final cable connections (the *ECS-25* has non-volatile memory) or at the control cabinet location after installation is complete, depending on administrator preference or convenience.

Section 3 – POWER REQUIREMENTS AND WIRING GUIDELINES

Power Requirements

The ECS-25 operates with 12 VDC @ 100mA. It is supplied with either a 12 VDC 600mA plug-in type converter or a power supply/charger, AC transformer and either a 4 ampere/hour or 7 ampere/hour battery, if standby power is to be used.

The *ECS-25* system was shipped with its own power supply designed to power the controller board, ComKey Reader and Request-To-Exit device. If you are using a locking device not supplied with the *ECS* system, check manufacturer’s specifications for load current required. Verify that it does not exceed the power supply’s output. If it does, you must use a separate power supply for the device.

Maximum power supply current output:

PS-50 12vdc plug-in type converter.....	600mA	@ 12vdc
PS-51 power supply/charger	1.2 amp	@ 12vdc
PS-52 power supply/charger	2.5 amp	@ 12vdc
PS-53 power supply/charger	4.0 amp	@ 12vdc

Wiring Guidelines

The wiring of the *ECS-25* system is an extremely important and integral part of the entire system. The cables should be run after the control cabinet location is determined and it is very important that proper wire is used to connect the technologies to the system.

For all installations:

- Avoid running data lines parallel to or in close proximity to high voltage lines or other sources of EMI such as motors, transformers, fluorescent lighting, etc., these are likely to interfere with data transfer affecting the ability of the system to function properly.
- It is recommended that data lines do not exceed 500 feet. Beyond this point the data transmission may degrade or weaken.
- Do not include locking device wires along side of the data cable unless the locking device wires can be separately shielded.
- Request-To-Exit devices can be wired using the same cable as the reader provided two additional conductors are available.
- Low capacitance cable is **strongly** recommended.

COMKEY Readers are connected using 26/6 flat wire with RJ12 plugs on each end that attach directly into both the Reader and the ECS-25 Controller Board.

If conduit is used for the wire run, the 26/6 wire may not withstand the stress of being pulled through the conduit. In this case the use of 22 to 24 AWG, 6 to 8 conductor, unshielded type CM data cable is recommended, with splices to 26/6 flat wire at each end for RJ12 connection. Suggested methods of splicing can be solder, crimp or terminal blocks.

Special connector modules may be obtained for joining the two cable types and to reduce installation time. These can be 'punch-down' type connectors such as AMP#H4-93830241 or equivalent. Surface mount 'quick-connect' type jacks such as Leviton #41036-IDA or equivalent may also be used. These jacks allow easy termination of multi-conductor cable, enabling 26/6 flat wire to be plugged in directly with RJ12 connectors (see Figures 1b and 1c).

Connecting 26/6 flat wire to RJ12 plugs

26/6 Flat Wire is used for connection between ComKey Readers and the ECS 25 Controller or as one method of connecting the Wiegand Format Converter to the ECS 25 Controller Board.

To construct the cable flat wire, RJ12 connectors and a crimp tool are needed, all of which are included with the kit.

The cable is standard telephone installation wire and the connection into the jacks must be reversed for communication to work. As a reference to ensure proper alignment, note that the cable has a smooth side and a raised seam side. If you install both RJ12 connectors release tab up, on the same side of the cable, you will insure proper alignment and functioning.

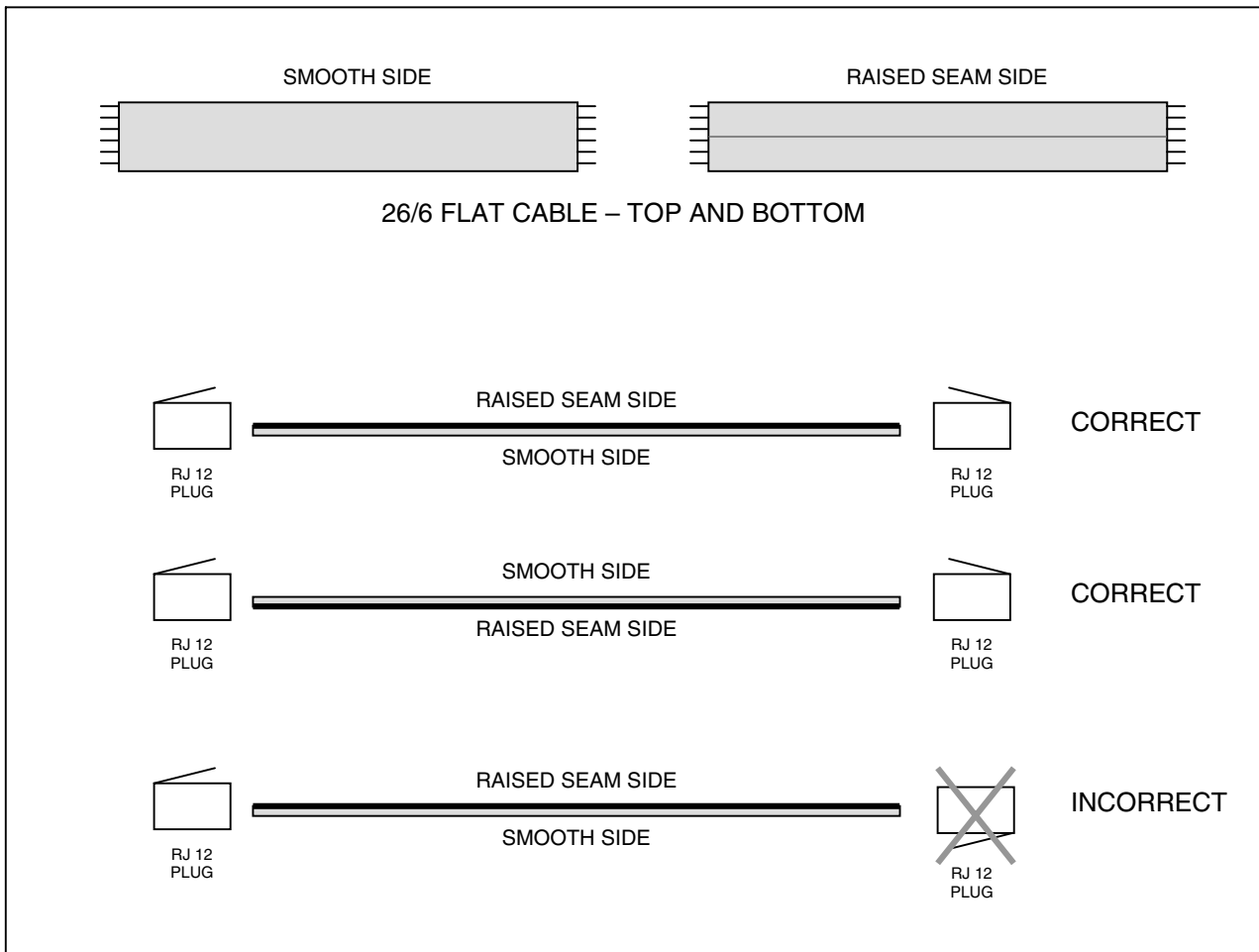

Figure 1a – RJ12 Plug Connection to 26/6 Flat Cable

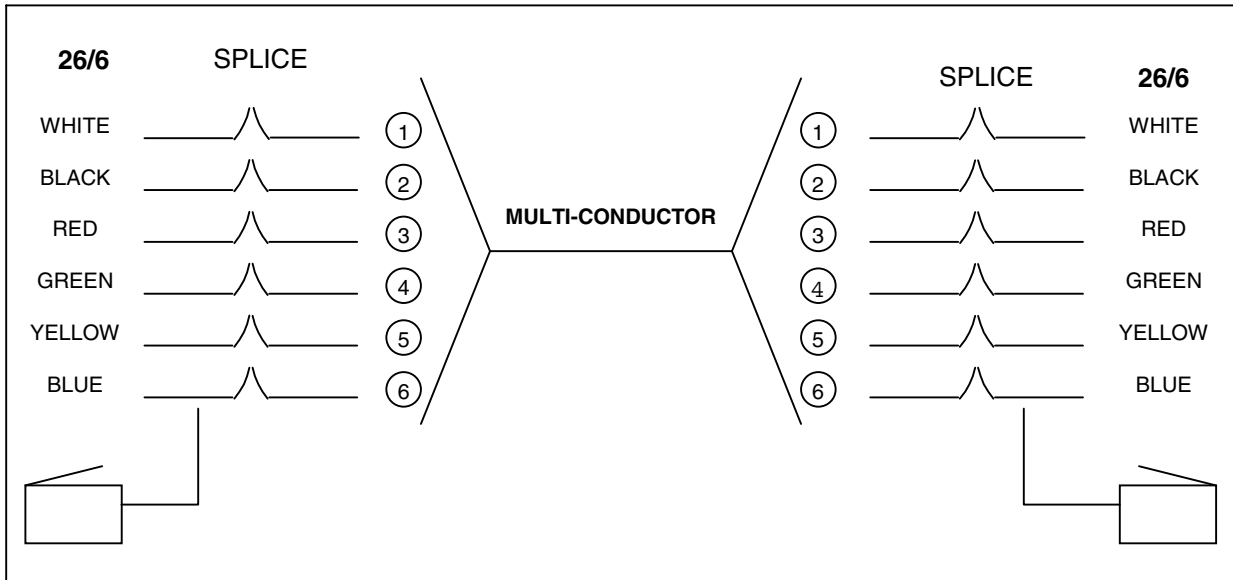

Figure 1b – Multi-Conductor Wire Splicing

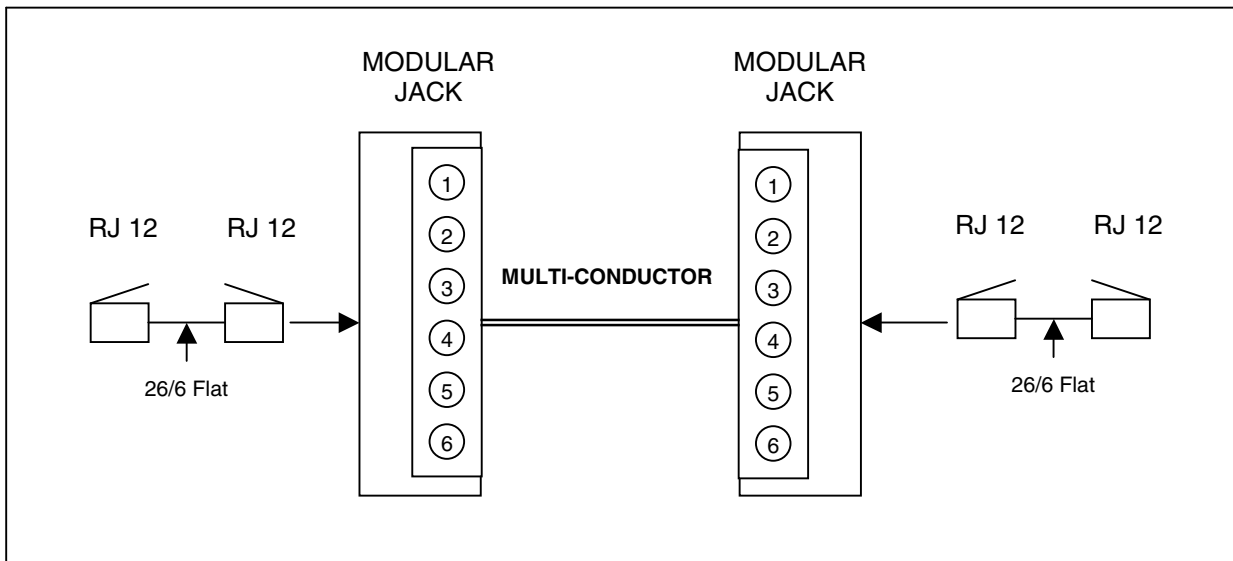

Figure 1c – Multi-Conductor Modular Splicing

Grounding

The unit must be properly grounded to protect it from the effects of static and lightning. Surge suppressors are recommended on power lines.

Attach a separate 12 AWG insulated wire to GND terminal and attach the other end of this wire to earth ground. This can be a properly grounded metal conduit, cold water pipe, or a grounding rod driven at least 10 feet into the soil. Keep the ground wire as short as possible.

If you are using a separate surge suppressor, it must also be grounded to function properly.

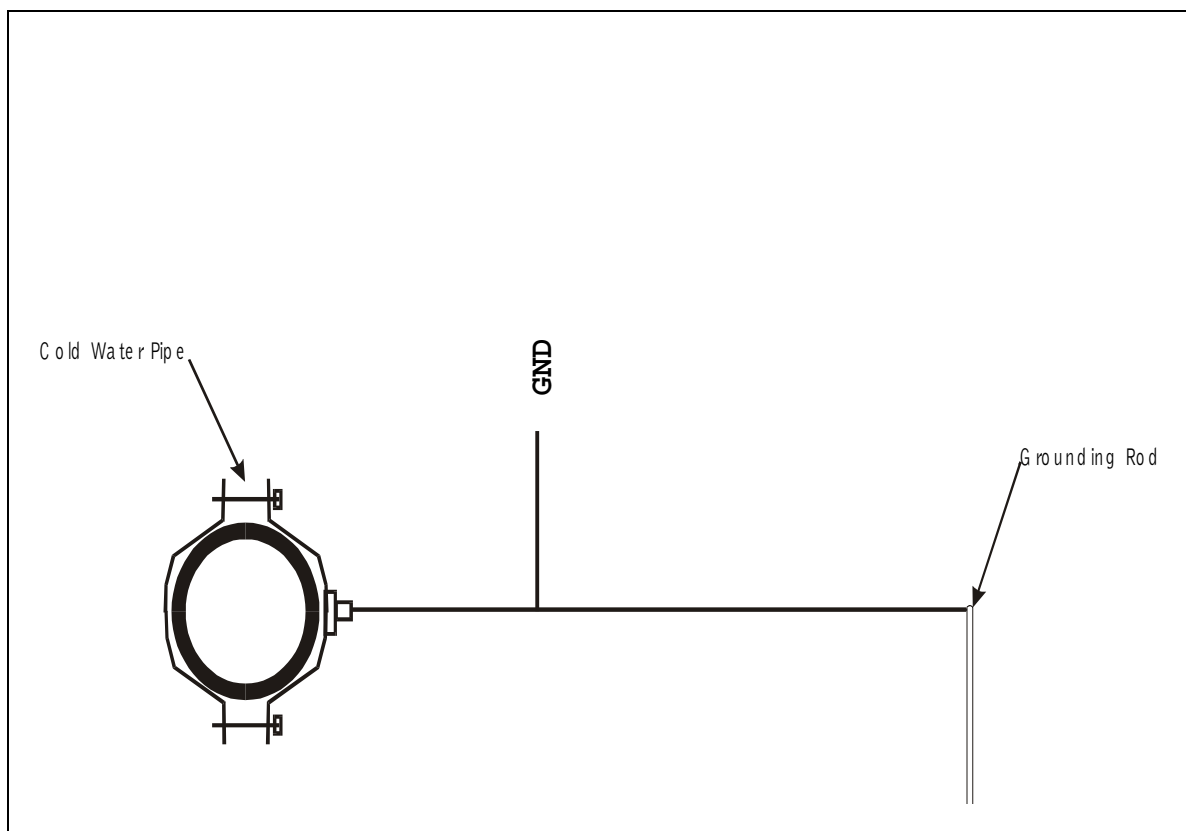

Figure 2 - Grounding the controller board

Section 4 – LOCATION AND MOUNTING GUIDELINES

The ECS-25 unit is housed in a control cabinet designed to be surface mounted to any wall. You must be certain to properly ground the cabinet to a good earth ground.

If an outdoor location is required for your installation, the unit must be housed in a weatherproof enclosure rated NEMA 4, for proper protection against moisture. **Temperature and humidity extremes may require additional steps to prevent unreliable equipment operation. If there are any concerns regarding the location environment, check with the manufacturer.**

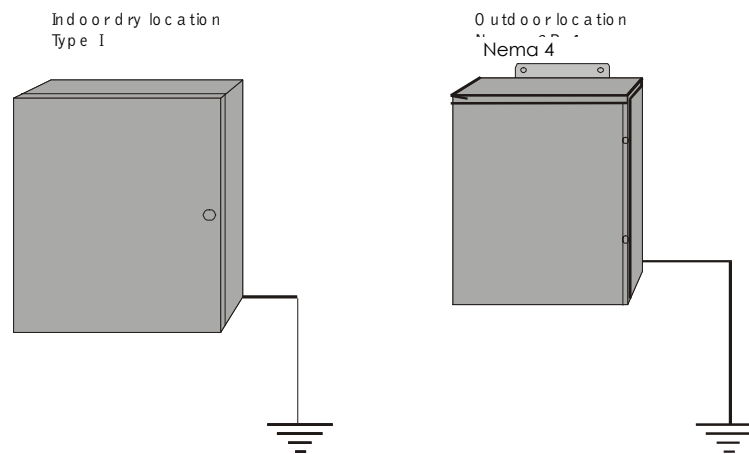

Figure 3 - Enclosure examples

Mounting the Enclosure

Choose a location where the control cabinet will not be exposed to moisture or leaks. Secure the cabinet to the wall surface with proper fasteners, then bring any conduit to the cabinet through knockouts provided. **Do not install any conduit through the top of the cabinet.**

It is recommended that the control board terminal strip be no further than 500 feet from your reader device location.

Be sure that power is available nearby for the transformer to be plugged-in. If power is not available nearby, you must have power brought to the location. **Do not use extension lines to power the unit.**

Once the Control Cabinet location is determined, cables can be run in accordance with the Wiring Guidelines outlined in Section 3 (page 6).

Section 5 – INSTALLATION

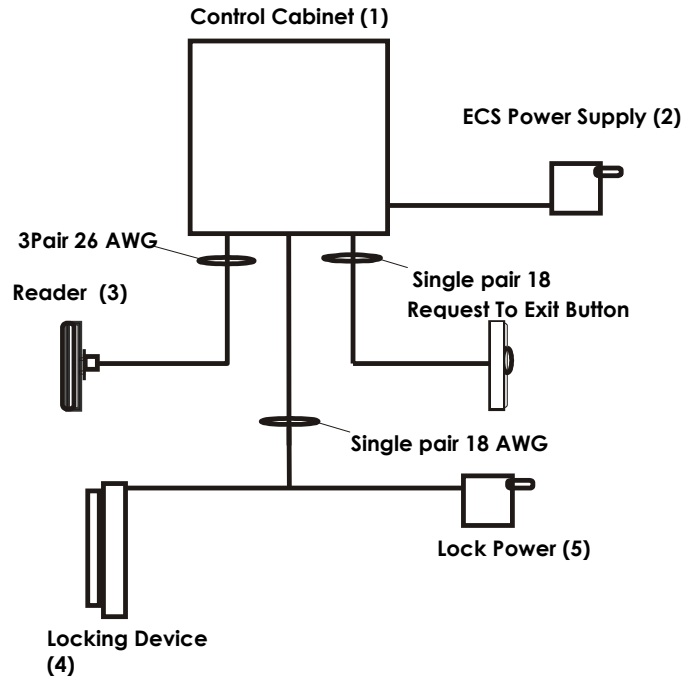

Figure 4 - Installation Block Diagram

Block Diagram Description		
1	Control Cabinet	Houses the ECS-25 Controller Board, Lock Control Relay and Wire Termination
2	ECS Power Supply	Plug-In type, 12 Volt DC
3	Reader	ComKey Reader technology connected with 26/6 flat line cord
4	Locking Device	Any type of fail safe or fail secure lock that is controlled by the ECS-25 output relay
5	Locking Device Power	A separate voltage source to supply a common to lock and device load through the relay
6	Request-To-Exit Device	If the locking device requires a relay control to provide egress, a normally closed switch is used

Installation Configurations

The ECS-25 standard installation utilizes a Normally Closed Momentary Push-To-Exit Button and can be configured with either Magnetic Locks or Electric Strikes (See Figures 5 and 6). Fail Safe or Fail Secure operation is determined by the type of locking device, not the connection to the controller board.

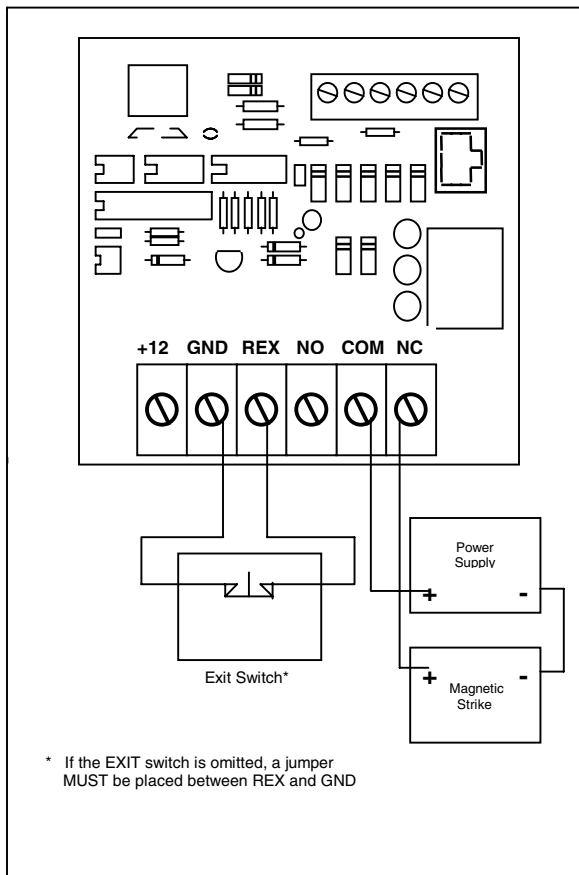

Figure 5 – Standard Installation Using Magnetic Lock

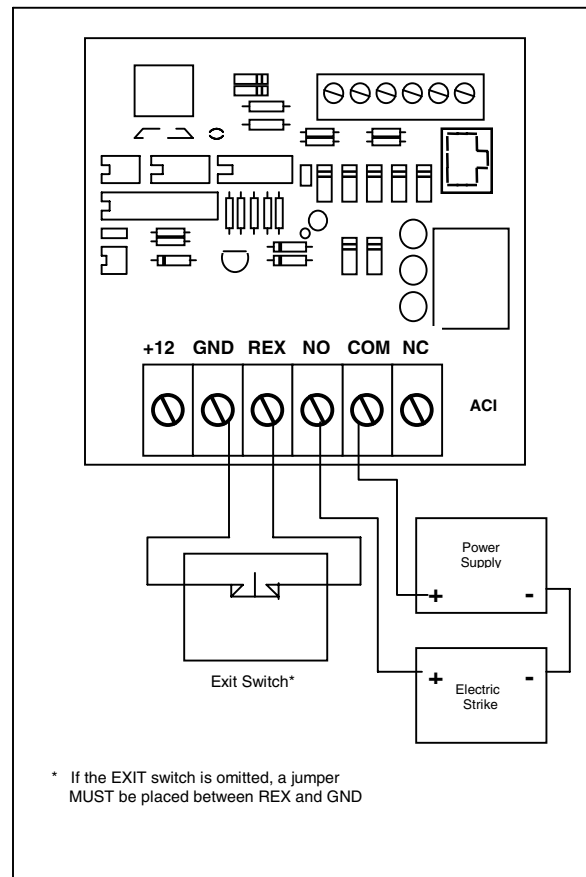

Figure 6 –Standard Installation Using Electric Strike

Installing Reader Technology

ComKey Reader

Slimline ComKey reader plates are designed to fit most door frames. The plate is surface mounted with the RJ12 connector block recessed behind it. Full size ComKey reader plates are designed to be either surface mounted on a wall or recess mounted using an electrical box.

If a request-to-exit push button is being used, it should also be installed at this point.

Typical push button height is 38" to 42".

Readers using other technology vary in their mounting requirements. In all cases, however, mounting heights and location should be considered for the end user.

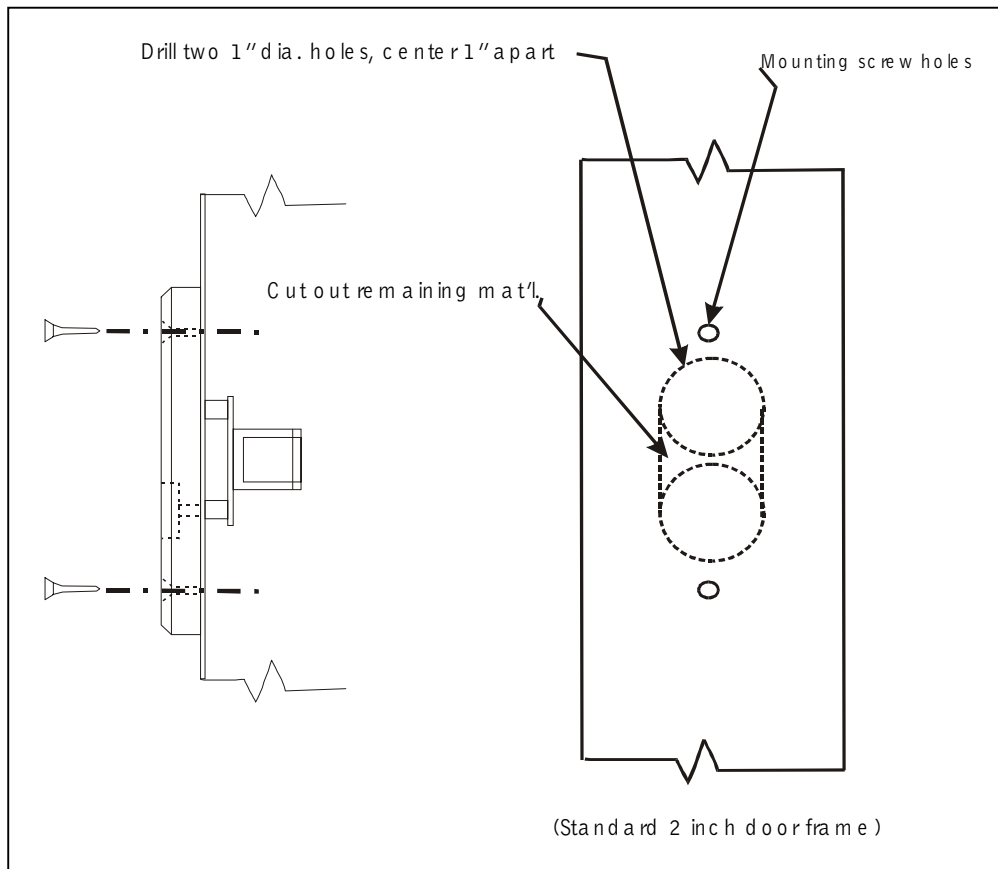

Figure 7 - ComKey Reader Installation

The reader faceplate is interfaced to the *ECS* controller board by directly connecting the 26/6 flat cable to location J1, with RJ12 connectors as shown. If an additional reader is being connected to the controller, use a six conductor modular Y adapter. Make sure that the RJ12 connectors are properly oriented on the flat wire as shown in Section 3 (Wiring Guidelines).

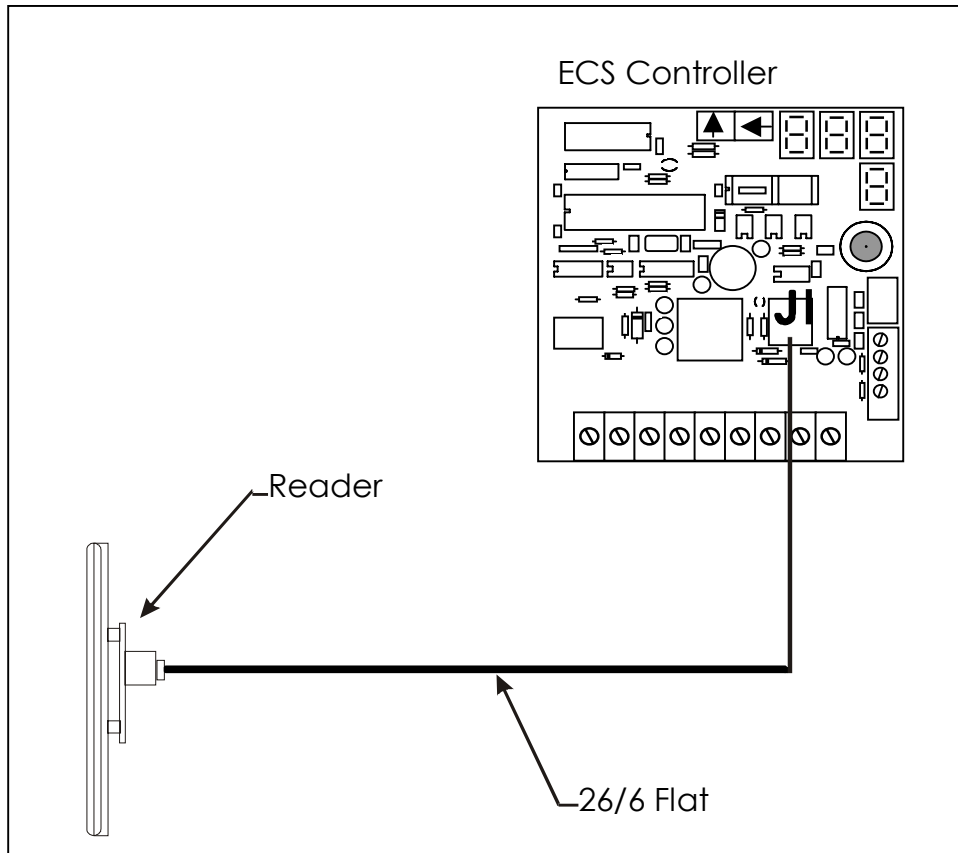

Figure 8 - ComKey Reader to Controller Connection

Section 6 – Final Connections

Verify that the ComKey Reader has been properly connected to its cable and that the RJ 12 connectors are correctly installed, referring to Section 3.

For devices that require a constant power source of 12 VDC, connect red wire [+12V] and black wire [-Neg ground].

If the *ECS* system is being used to control equipment with automated movement such as overhead doors, gates, or lifts, bring up power to the *ECS* first, then power up the equipment controlled by it. This will prevent sudden movement caused by the output on power-up. After the system is powered and running, the controller is ready to be programmed.

Note that the *ECS* - 25 uses non-volatile memory, and can be programmed on the bench prior to installing.

Com-Key Reader Faceplate

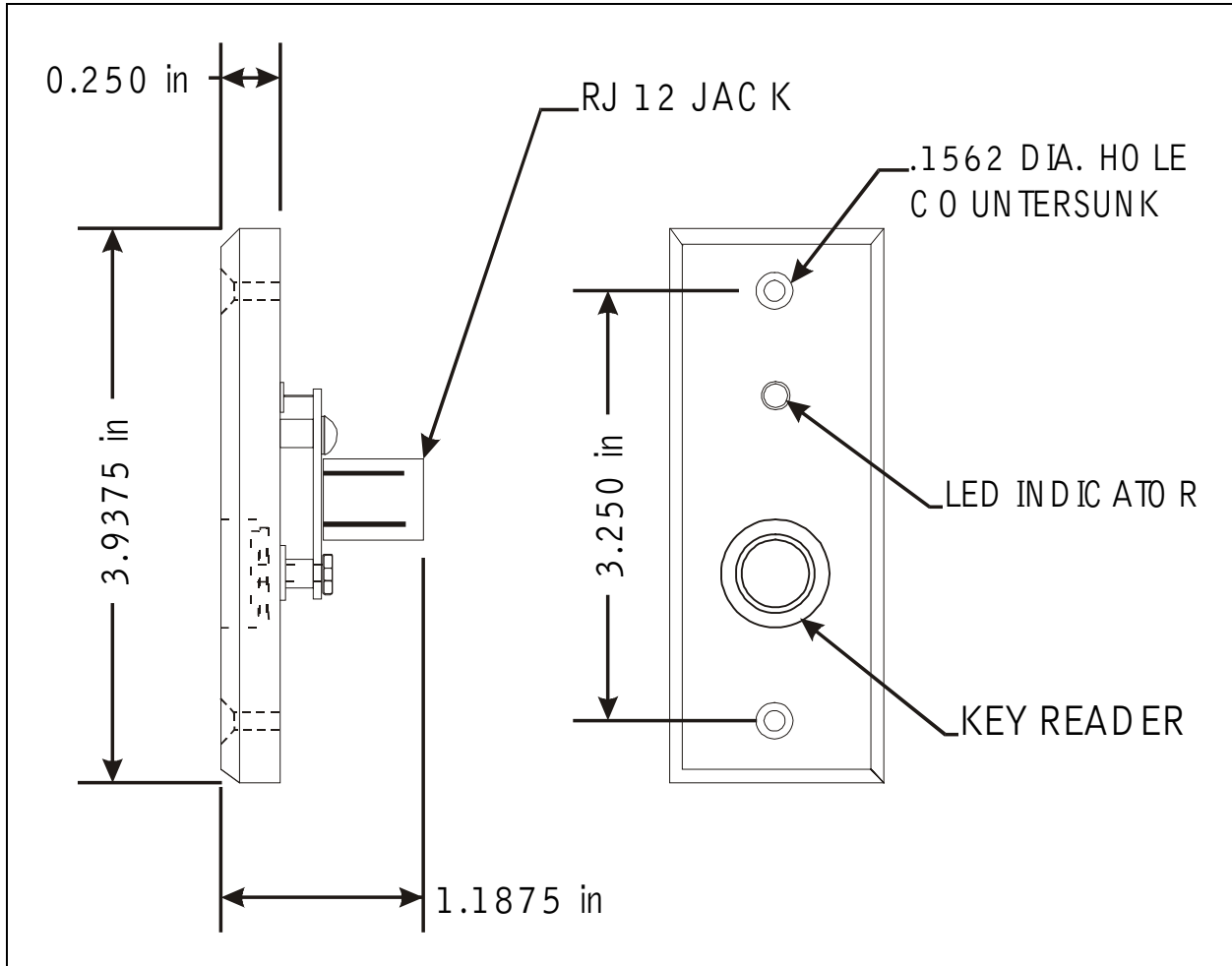

Figure 9 - Stainless Steel Slim Line ComKey Reader

- Slim line (shown) or full size ComKey reader plate connected to RJ12 jack on *ECS - 25* control board.
- Composite reader faceplate wired to TB2 terminal block on *ECS - 25* control board.

ECS Request to Exit Input

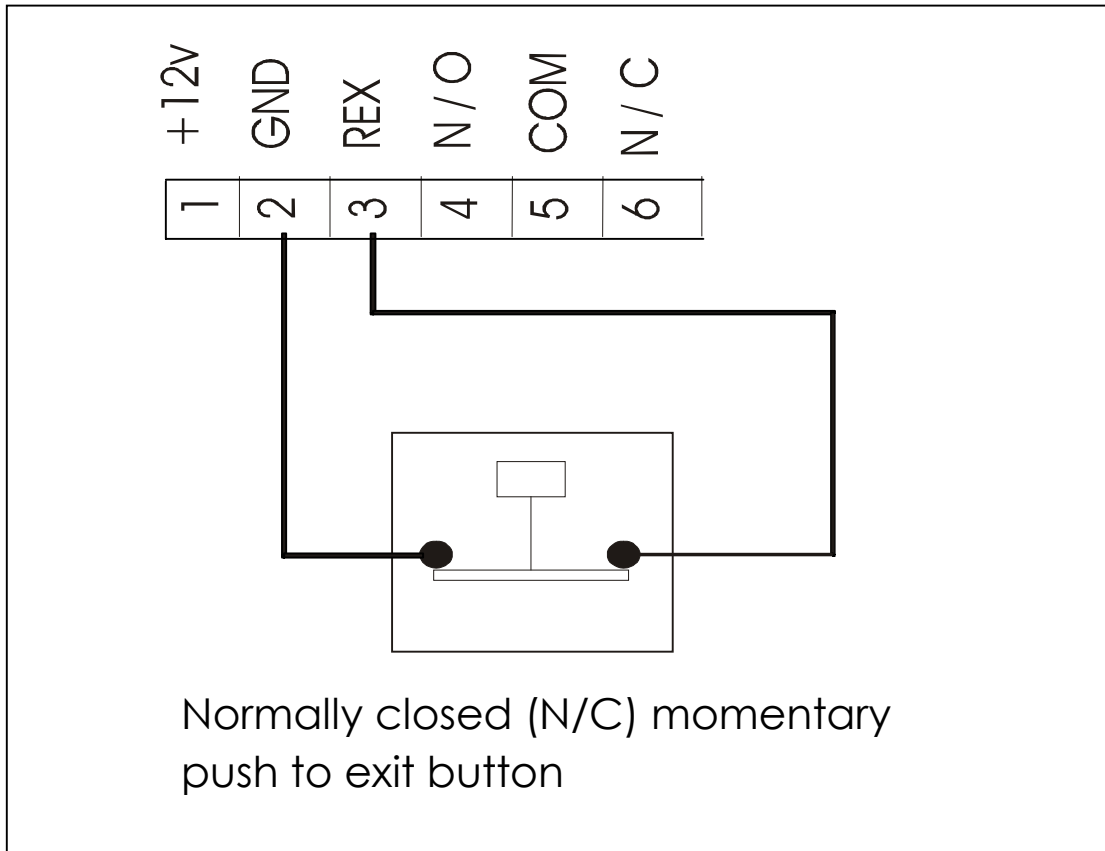

Figure 10 – Request-To-Exit connection

- A request-to-exit button must be a momentary, normally closed switch connected to Terminals 2 and 3.
- An “open” across 2 and 3 will not allow controller to recognize input from readers.
- If no input is connected to Terminals 2 and 3, a jumper must be installed.
- May also be connected to a latching output from equipment such as fire alarms.

ECS - 25 Power Wiring

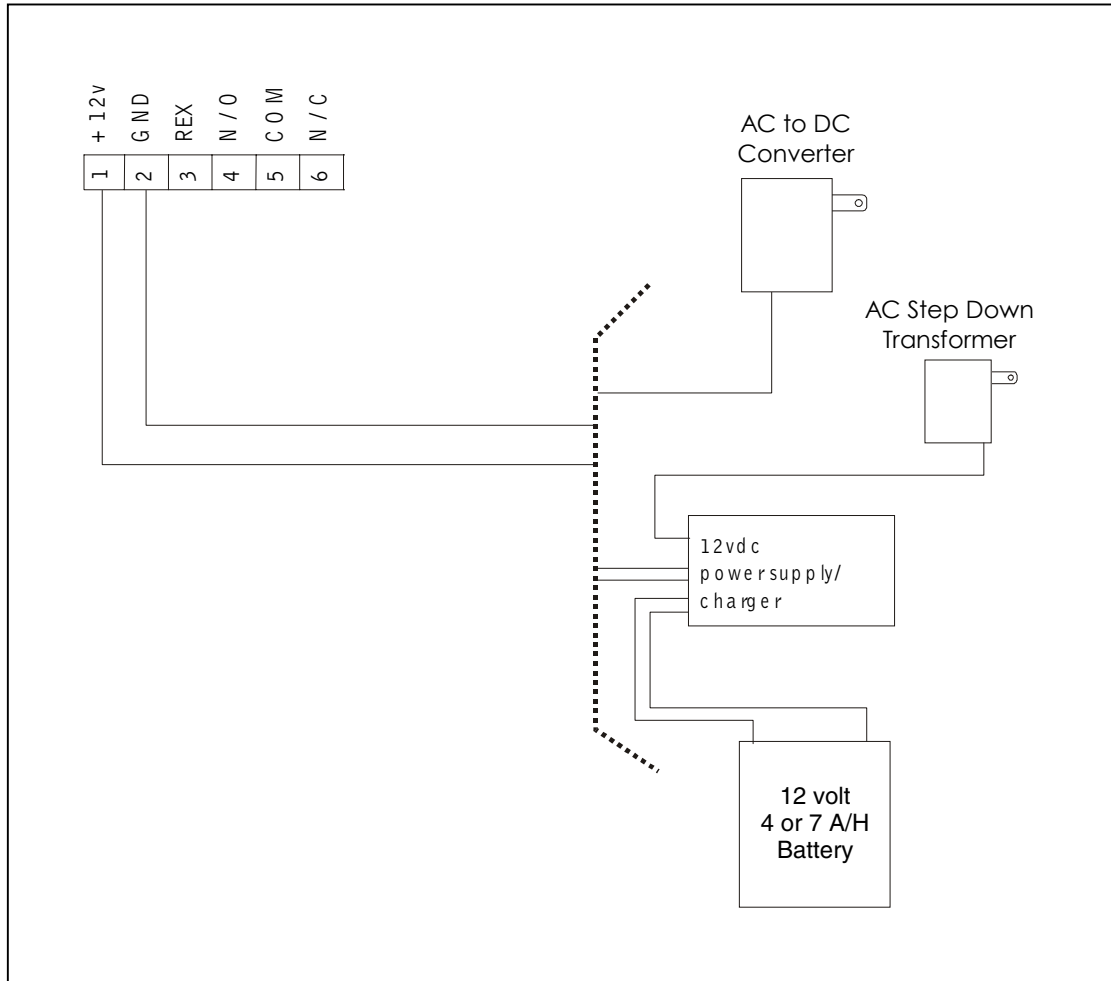

Figure 11 - Available power sources and wiring

- 12 VDC power connected to Terminal 1 and 2 on *ECS - 25* control board.
- Power supplied by DC plug-in type converter or optional standby battery backup with power supply charger.
- Electric strikes or magnetic locks must be powered by a separate transformer.

Control Component Logic

Component	Function
TB 1 Terminal Strip	For connecting power, request-to-exit and relay output.
TB 2 Terminal Block	For connecting composite reader output to LED indicators and backlight
J1 RJ Connector Jack	Type RJ jack for connecting 26/6 flat cable using RJ12 connectors
D11 LED	Light emitting diode to indicate when output relay has energized

Table 1

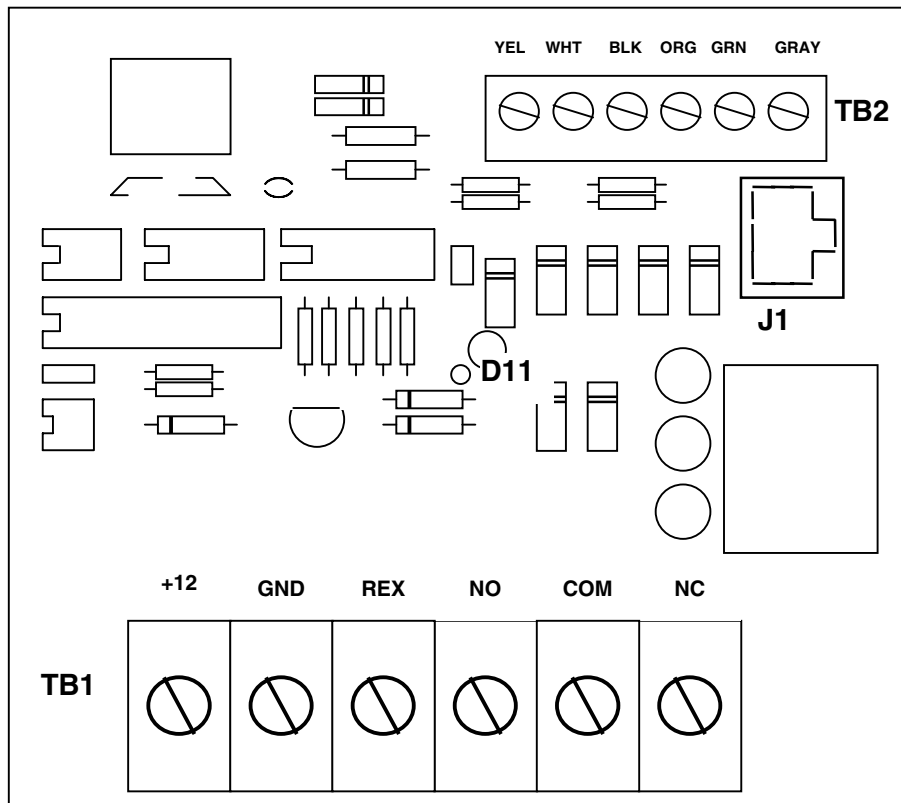

Figure 12 - ECS-25 Controller Board showing locations listed in Table 1

Section 8 - Troubleshooting Symptom Guide

A. No Output from Relay

1. Place a jumper across Terminal 2 and 3 (GND and REX) on the control board. If relay LED D11 goes out, there is an open in the request to exit circuit.
2. Check for improperly connected reader. Disconnect any key readers from control board. If relay activates, the reader or wiring is at fault.

B. No Key Read Indicated At Reader Plate

1. Connect a voltmeter across the key reader POS + to center conductor neg – to reader plate, and verify that there is 5 VDC present. If voltage is not present, check all connectors and splices in the reader cable.
2. Disconnect power to control board, wait 15 seconds and reconnect. If system now operates, be sure the load on the relay contact has not exceeded its rated specification. High contact load may require the use of surge/noise suppressors.
3. Substitute the reader with a new one, the LED may be at fault.
4. Verify that RJ12 connectors between reader and board are correctly oriented on cable and no short or open exists between each end.

C. Request to Exit Button Will Not Activate Relay

1. Make sure there is no jumper across Terminals 2 and 3 (GND and REX).
2. Check for 12 VDC across Terminals 1 and 2 (+12V and GND).
3. Disconnect the input from Terminals 2 and 3, connect a continuity tester across these wires. Circuit should be closed, and should open when button is pressed.
4. Disconnect reader cable at each end and verify that there are no shorted connections in the six conductor cable.

Section 9 – Specifications

ECS 25.....	100 mA max
ECS 100	300 mA max
ECS 200	300 mA max
ECS 400 and Turbo	500 mA max
ECS Printer Module	< 50 mA
ECS Data Format Converter	< 50 mA
Temperature range	32 °F to 158 °F
Relative humidity.....	85 % or less

Section 10 Dimensions

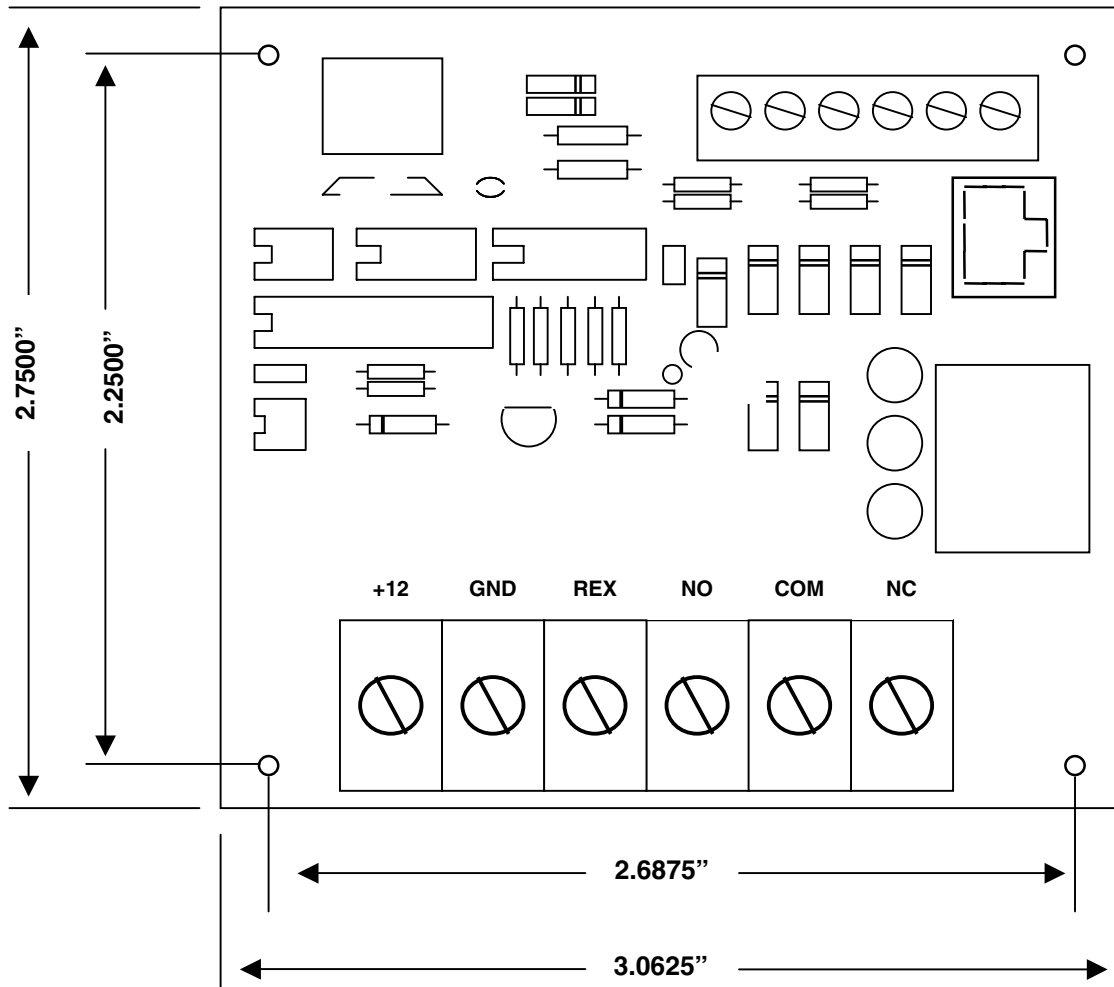

Figure 13 – ECS-25 Controller Board Dimensions

- Mounting hole locations -center to center
- Controller board dimensions –corner to corner

NOTES

NOTES