

Protector

Technical **Installation** **Guide**

Last Updated : Jan 31, 2005

TABLE OF CONTENTS

SOFTWARE INSTALLATION.....	3
PROTECTOR NETWORK SYSTEM SPECIFICATIONS.....	4
FIRE ALARM CONNECTIONS	4
POWER REQUIREMENTS.....	4
CABLE REQUIREMENTS.....	5
PANEL INSTALLATION REQUIREMENTS.....	5
RS232/485 CONVERTER WIRING TO PANEL	6
PROTECTOR 4 DOOR CONTROLLER SPECIFICATIONS.....	7
WIRING POWER.....	8
WIRING READER.....	9
WIRING EXIT BUTTON / DOOR CONTACT.....	9
WIRING EXIT BUTTON / DOOR CONTACT.....	10
WIRING DOOR LOCK.....	10
WIRING DOOR LOCK.....	11
WIRING AUX RELAY	12
ONE READER DOOR TYPICAL	12
ONE READER DOOR TYPICAL	13
TWO READER DOOR TYPICAL.....	14
SMART IO 8 CONTROLLER SPECIFICATIONS.....	14
SMART IO 8 CONTROLLER SPECIFICATIONS.....	15
ELEVATOR CONTROLLER SPECIFICATIONS.....	16

ELEVATOR CONTROLLER LAYOUT.....	17
ELEVATOR EXPANSION MODULE CONNECTION.....	17
ELEVATOR EXPANSION MODULE CONNECTION.....	18
DIAL UP MODEM CONFIGURATION	19
TCPIP CONFIGURATION USING LANTRONIX UDS-10	22
UDS-10 RS485 WIRING.....	22
UDS-10 RS485 WIRING.....	23
EVERSWITCH KEYPAD WIRING DIAGRAM.....	23
EVERSWITCH KEYPAD WIRING DIAGRAM.....	24

PROTECTOR NETWORK System Specifications

- Supports 65,000 users
- Unlimited Site Codes
- Number of field panels limited only to the number of Channels used and the power of the main server.
- Virtually unlimited doors.
- 255 access privileges
- 200 time zones
- 30 Holidays
- Timed Anti-pass back with individual, back to back, or panel level Anti-pass Back
- Software user privileges support using passwords
- Windows 98 and up support
- 5 Client Work Stations
- Extremely simple installation and configuration
- Full reporting support
- Fully distributed system (field panels contain all information to operate on their own with no connection to P.C.)
- Elevator Support
- Input Output Panel Support
- Multi Site Dial Up
- Multiple Communications Ports
- Multiple TcpIp Channels

Fire Alarm Connections

NOTE: Access control system should not threaten life safety! Please ensure that system installation complies with local and state fire and building codes.

A contact from fire alarm panel must be used to break power to door locks in case of fire or emergency.

Power Requirements

Each Door Controller requires its own 12V 40VA transformer.
Optional Stand by battery is 12VDC 7AH.

Each board is designed to supply power to Reader(s), and to charge backup battery.

Each board is designed with Poly fuse. If fuse is tripped, disconnect all power for 30 seconds allowing fuse to cool off, then reapply power.

Each board has power LED indicator to show both 5V and 12VDC presence.

Cable Requirements

Interface	Maximum Distance	Cable Type	Code
P.C. to RS233/RS485 Converter Box	6'	Dos DB9 Female/Male Serial P.C. cable RS232	Depends on Manufacturer
RS232/RS485 Converter Box to Panels	4000' (1230m) Ideal Conditions	3 pair shielded 22GA.	Belden 8777
Readers to Panel	500' (152m) Ideal Conditions	3 pair shielded 22GA.	Belden 8777
Door Strikes / Magnetic Locks to Panel	500' (152m) Ideal Conditions	1 pair 18 GA.	Standard Bell Cable

Panel Installation Requirements

Qualified, licensed personnel should only do the installation and wiring of the access control system.

The panel mount must be **Solid, Rigid and Vibration free.**

The electrical connection must have a good earth ground, as this is imperative for proper operation.

Allow adequate access for servicing of the panel and wiring.

Provide adequate ventilation to prevent panel overheating.

Protector Bus Connections

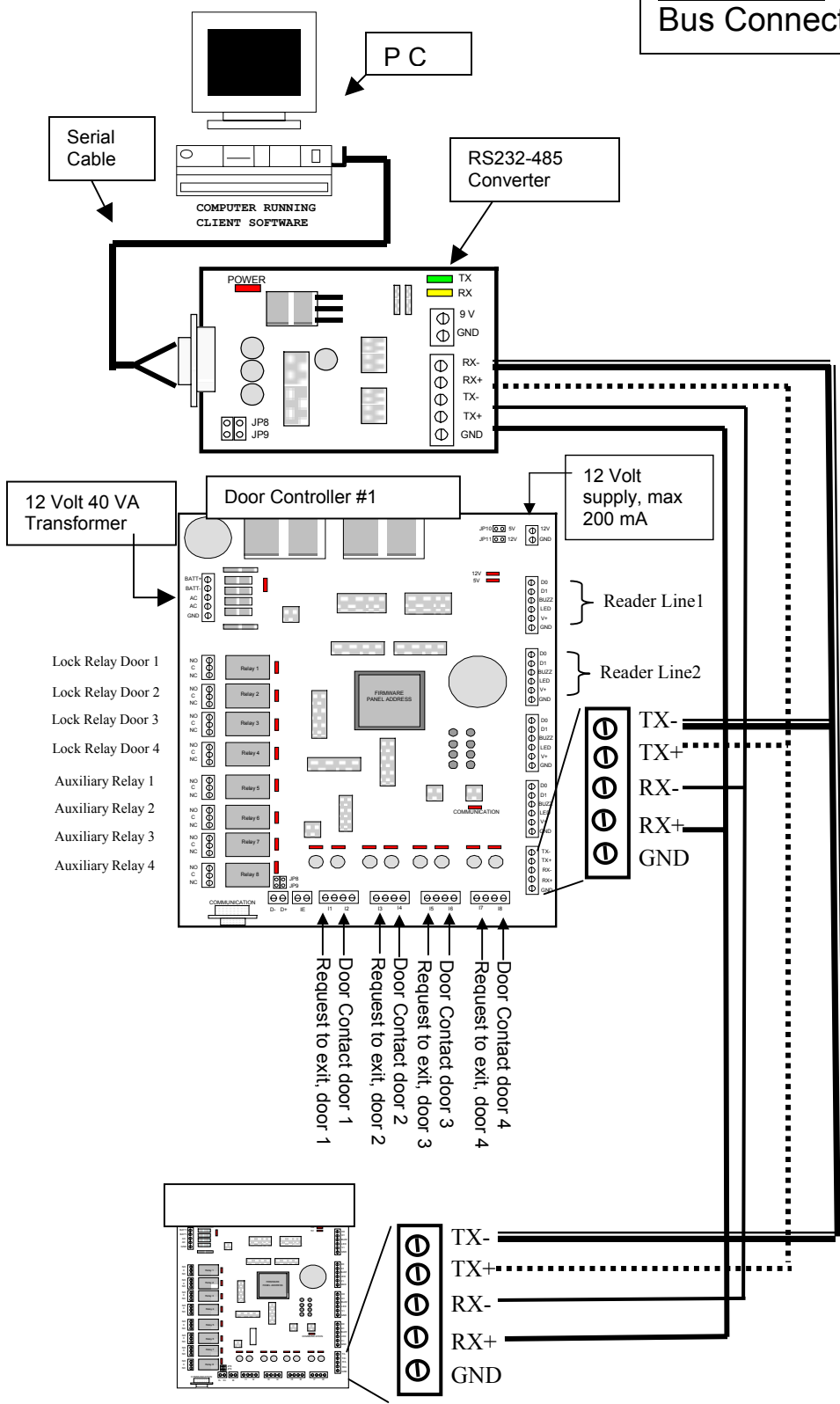

Use twisted pair for communication bus.

RX-/RX+ SAME TWISTED PAIR
TX-/TX+ SAME TWISTED PAIR
 CAT 5 for runs under 1000 feet, over 1000 feet use Beldon 8777.

From Converter RX- connect to TX- of first controller. Additional controllers, run from TX- of first controller to TX- of second, third, etc. controllers.

From Converter RX+ connect to TX+ of first controller. Additional controllers, run from TX+ of first controller to TX+ of second, third, etc. controllers.

From Converter TX- connect to RX- of first controller. Additional controllers, run from RX- of first controller to RX- of second, third, etc. controllers.

From Converter TX+ connect to RX+ of first controller. Additional controllers, run from RX+ of first controller to RX+ of second, third, etc. controllers.

If required terminate both end points of bus (RS232-485 Converter and last panel) using 100 ohm resistors.
 Terminate RX- & RX+

Communication wire, use 22 Gauge.
 Electric Strike wire, use 18 Gauge.

Reader wire, see Manufacturer's Specification.

PROTECTOR 4 door Controller Specifications

- Supports 4 card readers
- Battery back up Circuitry
- On board firmware clock
- Supports Wiegand 26 bit format, 36 Bit VerA (other on special request)
- 65,000 user on board storage
- 2000 event on board storage
- 4 Lock Relays
- 4 Auxiliary Relays activated by door alarms, card shunting or time zones.
- 4 Exit button and 4 Door contact inputs
- Power Requirements: 12VAC @ 40VA transformer
- Option Stand By battery 12VDC 7.0Ah
- Relays are Form C contact rated at 10A 125VAC
- On board LED to indicate communications, Active Relays, AC source, as well as state of inputs.

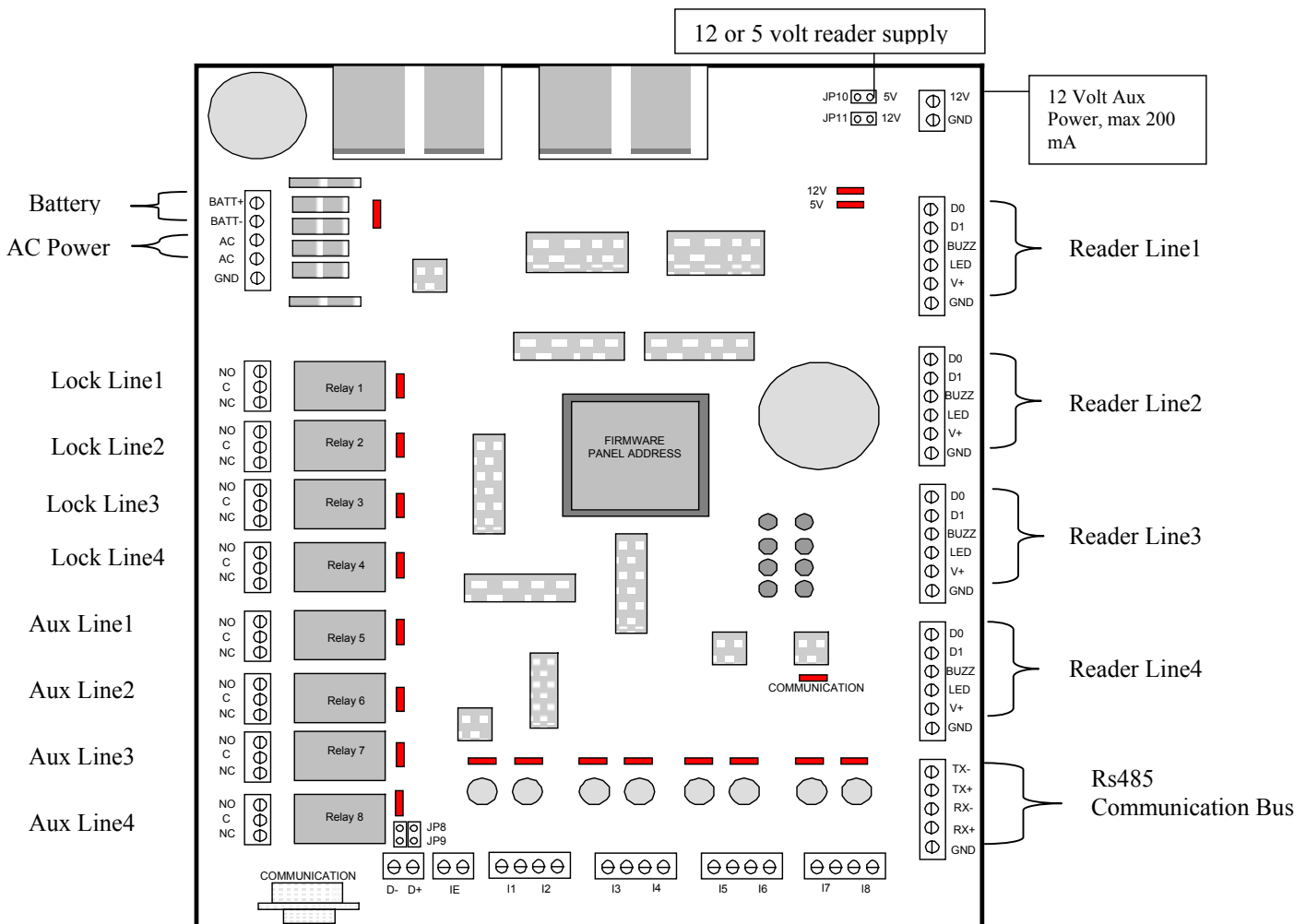

Wiring Power

A 12 Volt 40VA CLASS 2 CSA/UL approved transformer is required. The transformer must be located within 30 feet of panel and can only power one panel. Ground must be connected to cold water pipe ground.

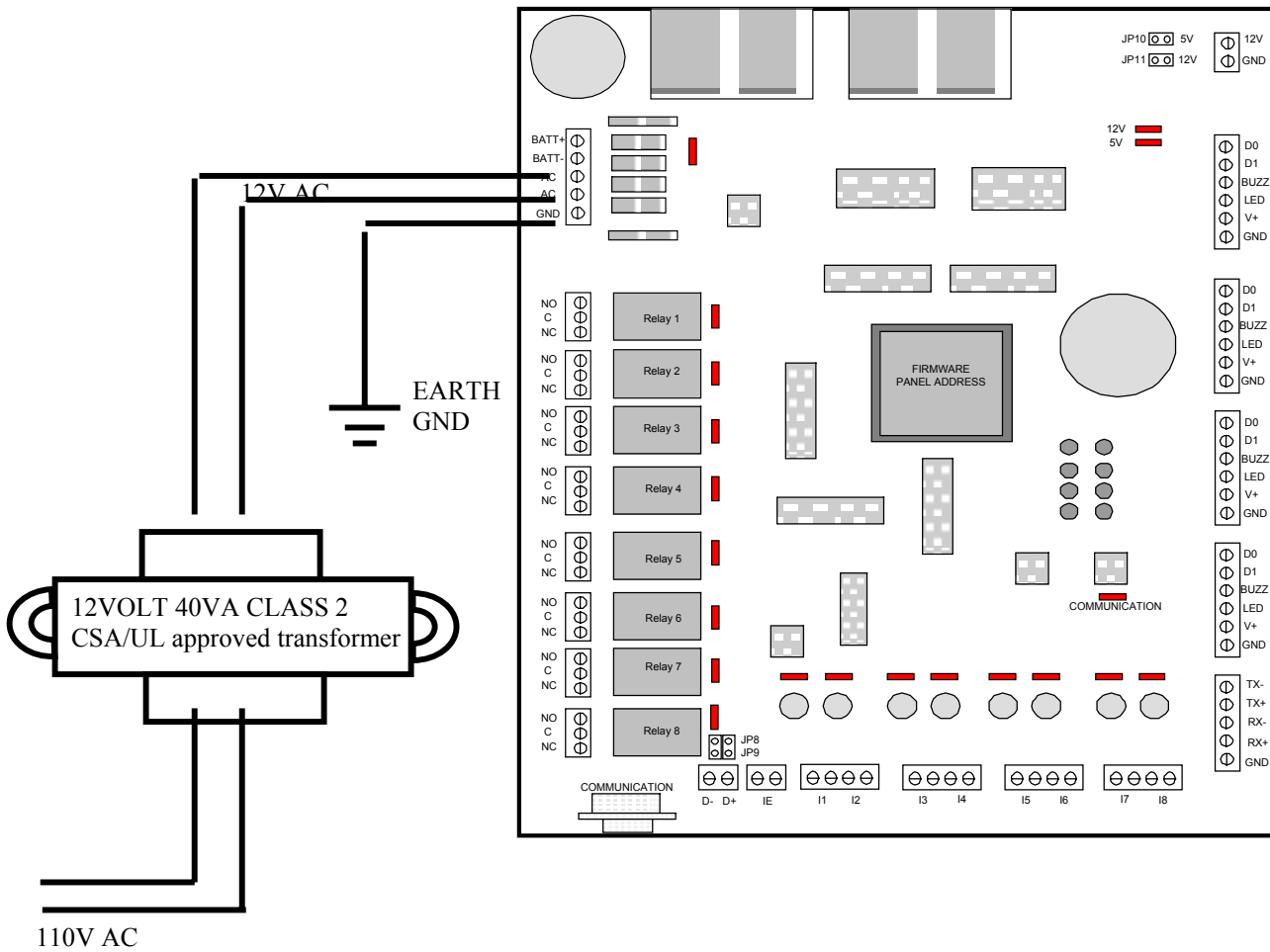

Wiring Reader

Standard 26Bit Wiegand format readers are connected as shown below.

Panel provides 12-13 volt DC output for readers

Leave shield floating at reader and connect to ground at panel.

Maximum reader distance is 500 feet.

Each reader is connected identically, as shown below.

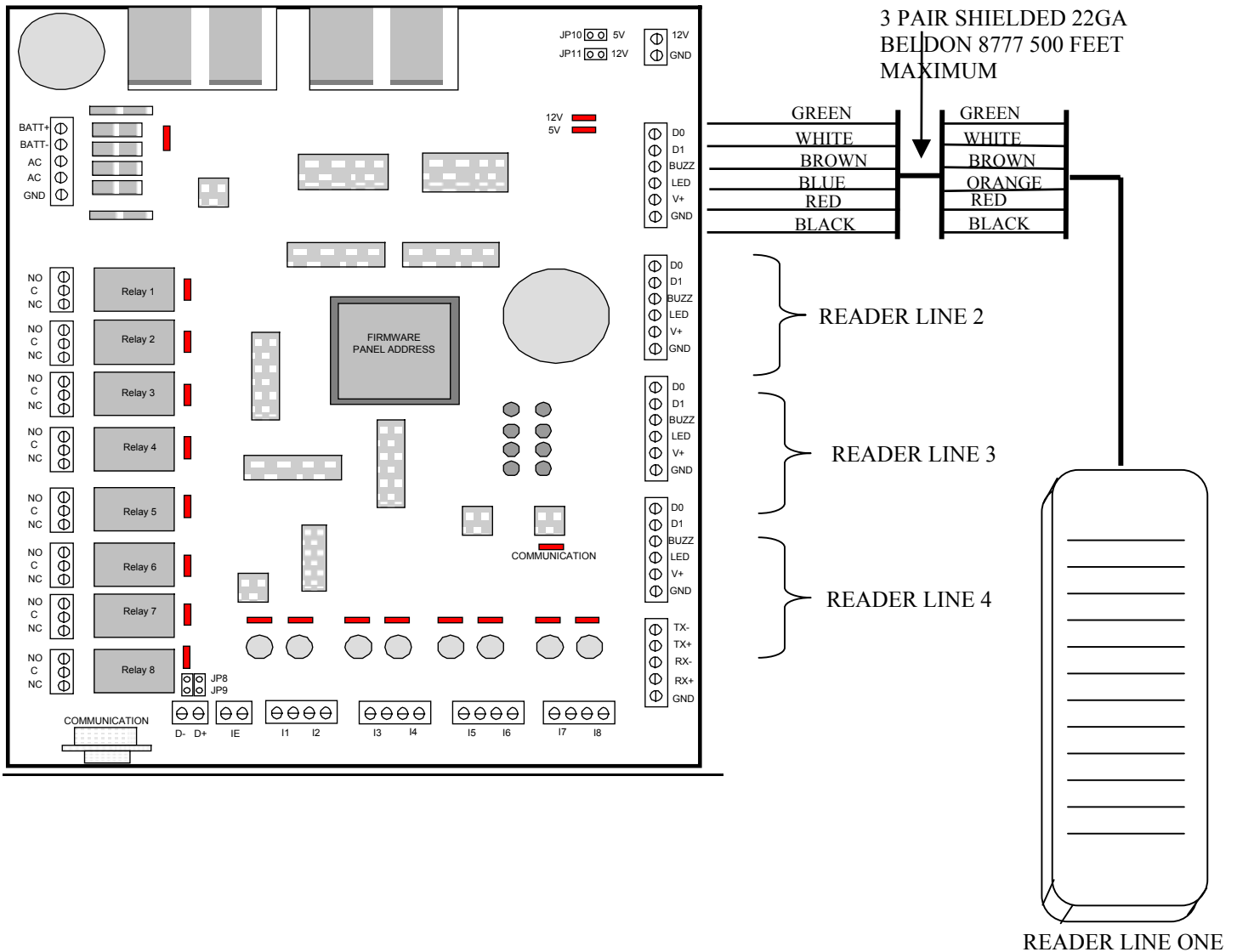

Wiring Exit Button / Door Contact

Exit button must be normally open dry contact.

Each exit button is connected exactly as shown bellow.

Exit button will unlock door for programmed time, and will reset the held open timer.

Door contact must be normally closed dry contact.

Each door contact is connected exactly as shown below.

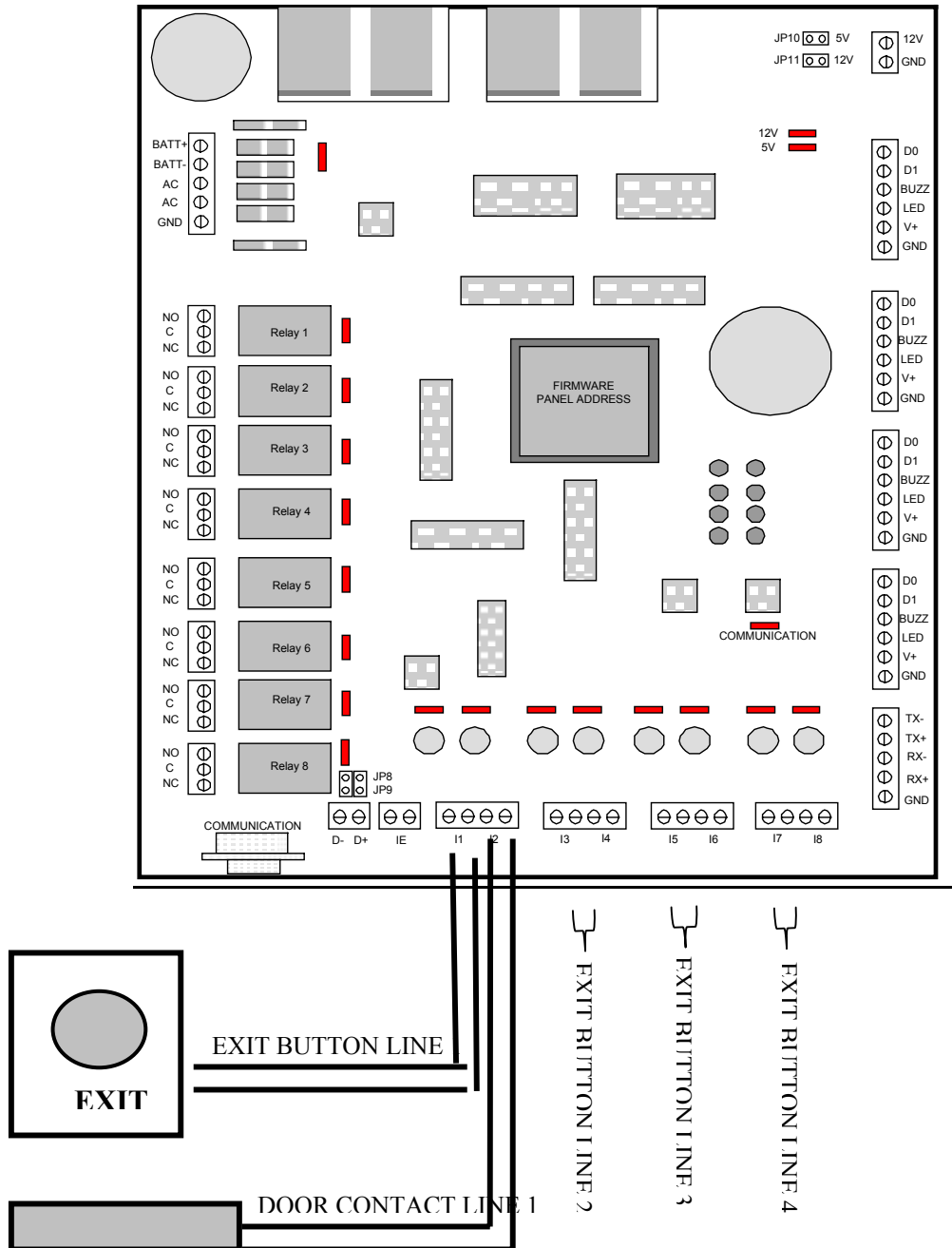

Wiring Door Lock

Relay LED Indicator is on when door is in unlocked and off when door is locked.
 If fire alarm activates, power to door locks must be broken before reaching access panel.
 External power supply is required for door locks.

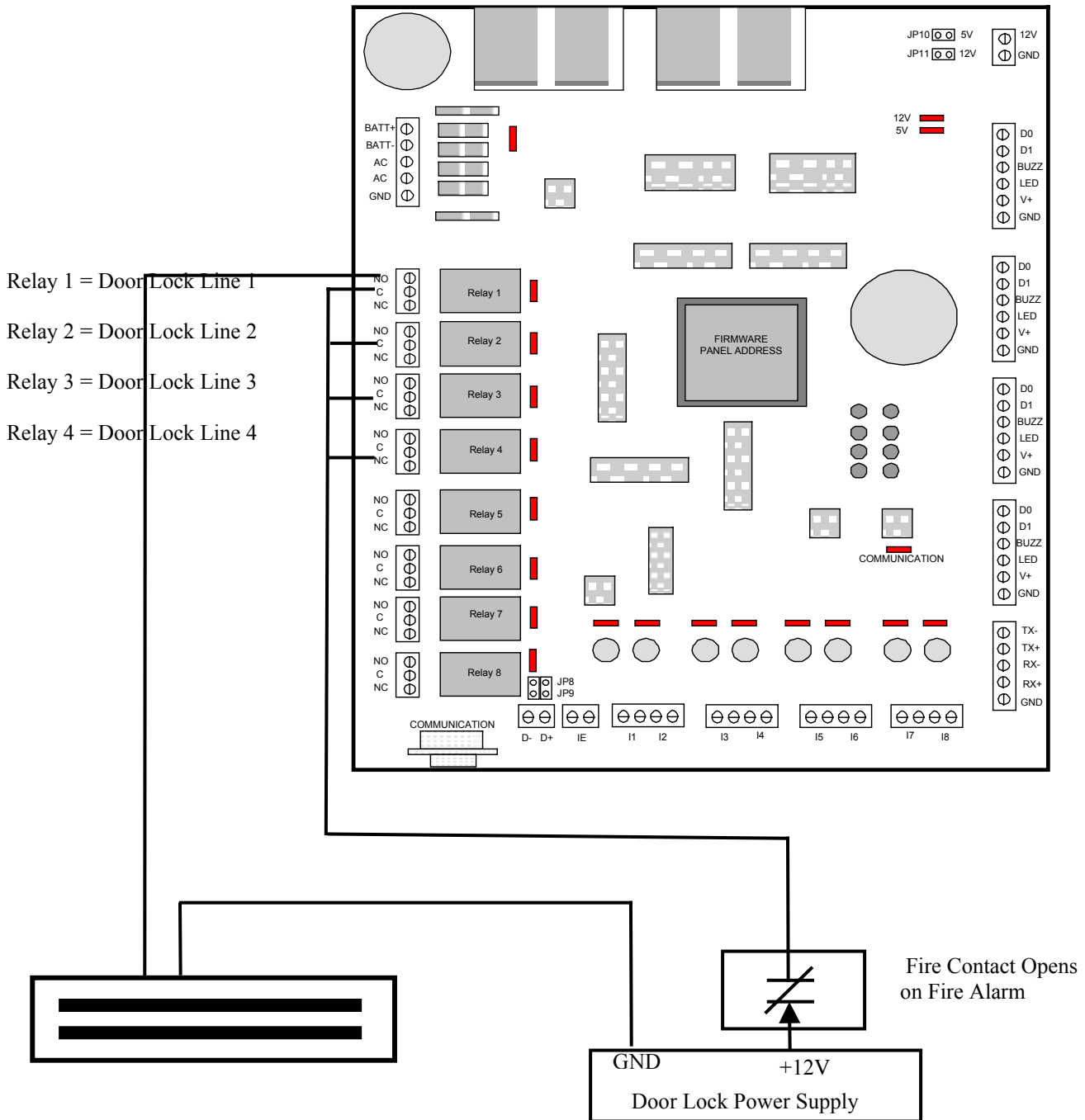

Wiring Aux Relay

When in active state, relay will be energized and LED will be on.

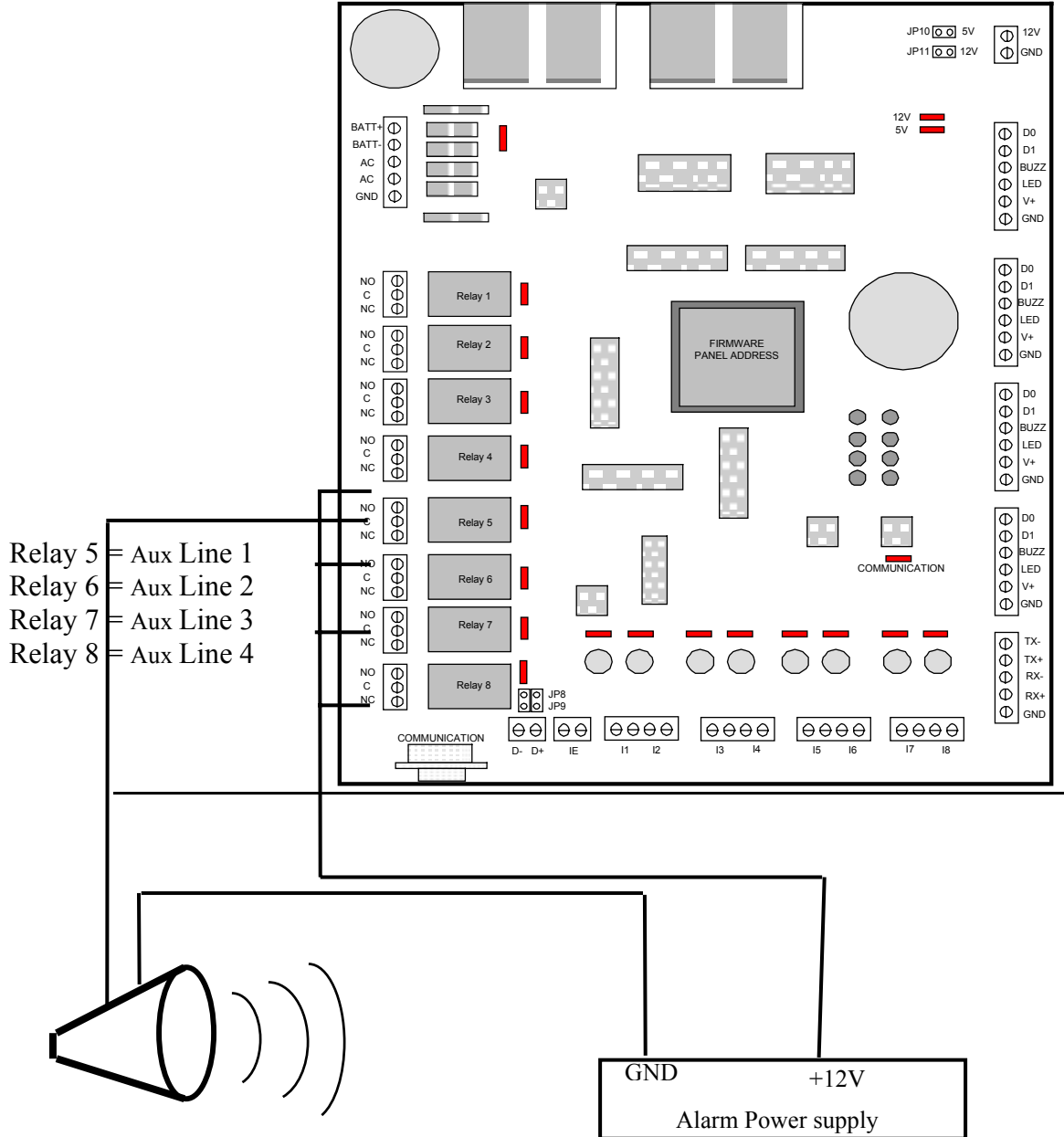

One Reader Door Typical

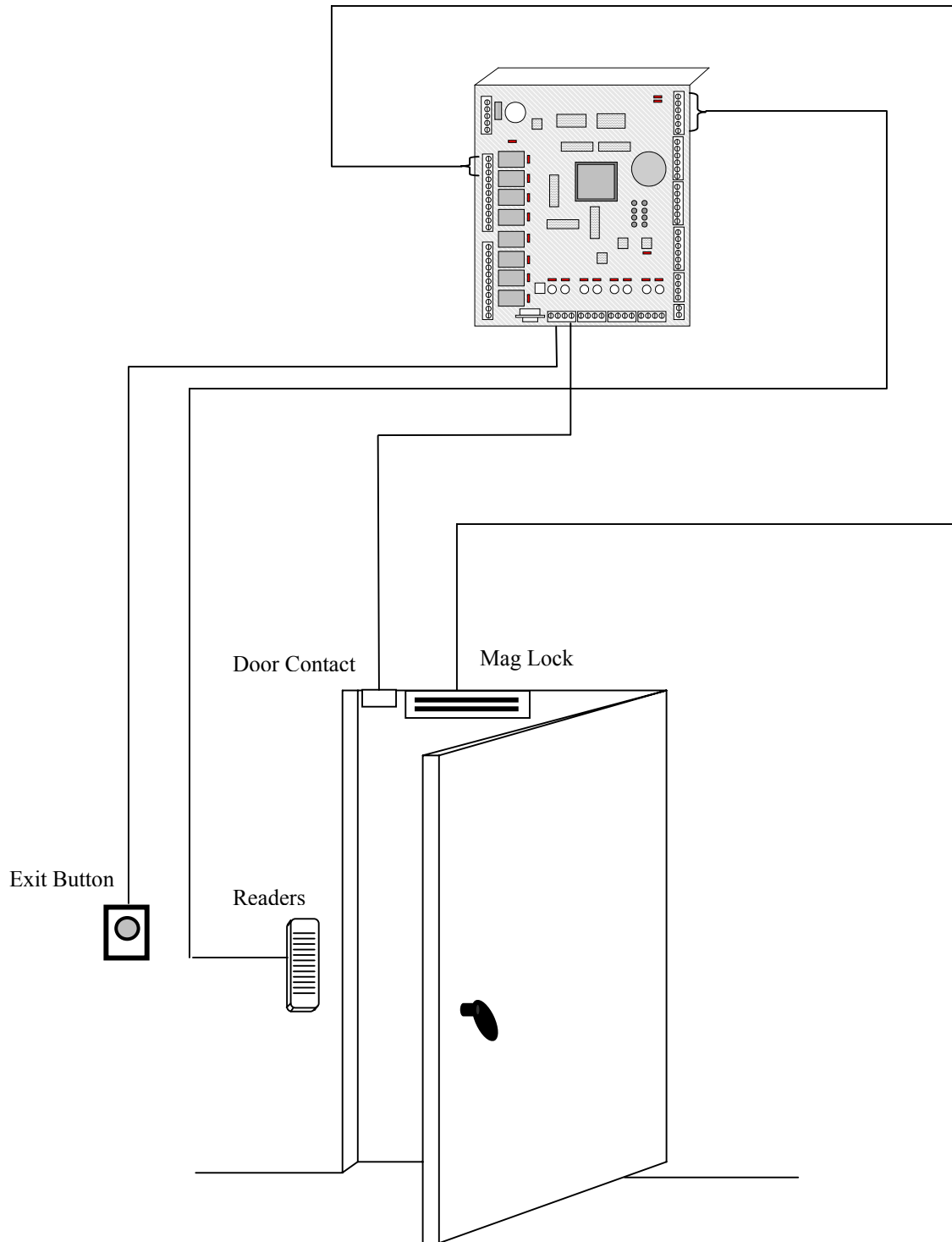

Two Reader Door Typical

When there are 2 readers on a door, the panel must be configured as either line 1 and 2, or line 3 and 4. Connect the lock, door contact and exit button to line 1.

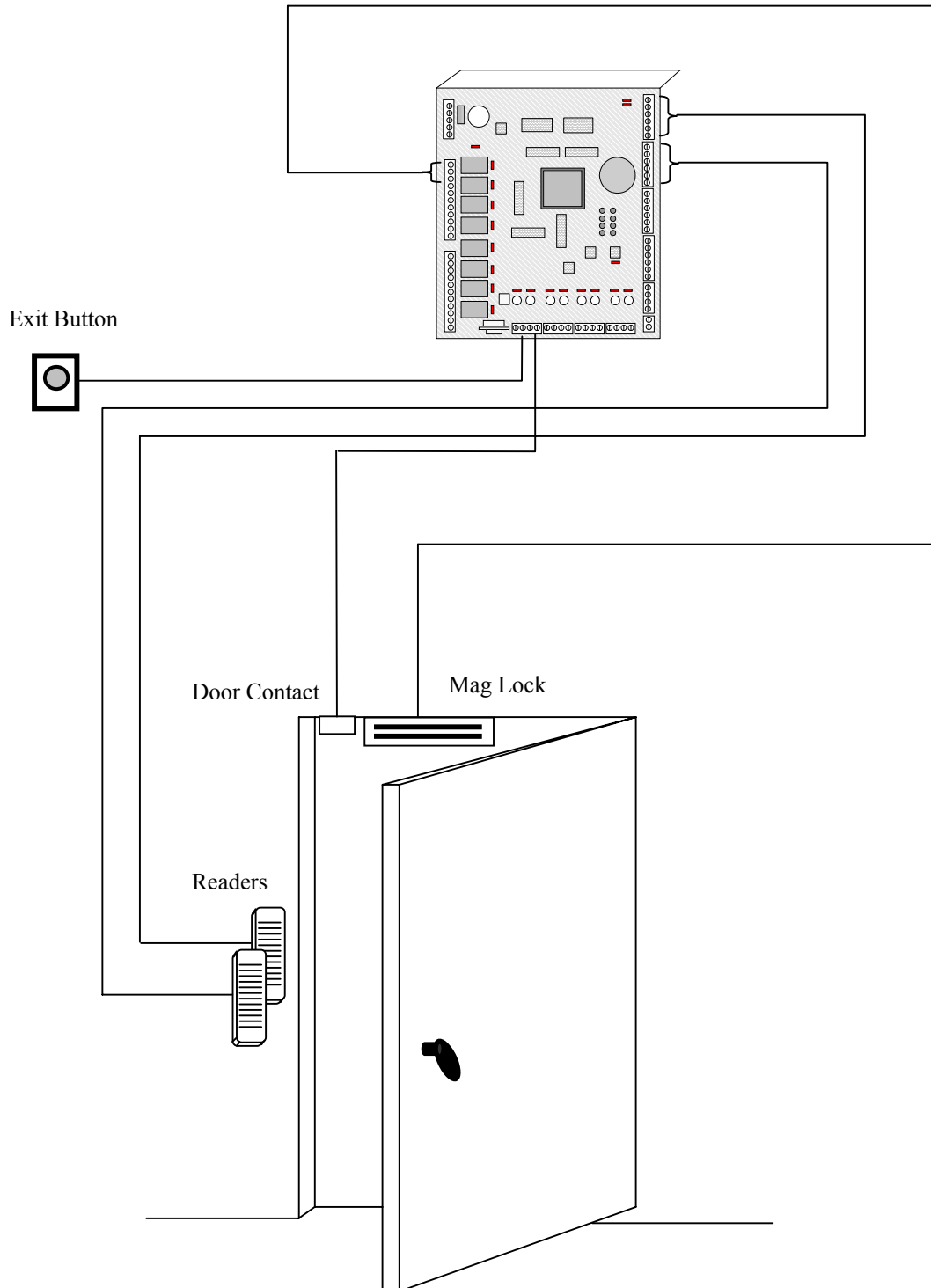

Smart IO 8 Controller Specifications

- 8 Output control
- 8 Unsupervised Input Control
- Battery back up Circuitry
- On board firmware clock
- 2000 event on board storage
- Power Requirements: 16.5VAC @ 40VA transformer
- Option Stand By battery 12VDC 7.0Ah
- Relays are Form C contact rated at 10A 125VAC
- On board LED to indicate communications, Active Relays, AC source, as well as state of inputs.

The Smart IO8 is a stand-alone unit similar to our door controllers. Each IO Panel has a unique address indicated on PLCC chip in center of board. Inputs are programmed to arm according to assigned time zone. Outputs can be programmed to activate according to an assigned time zone or to follow input for buzzer activation etc. This Panel operates fully independent of Server or other panels on the network.

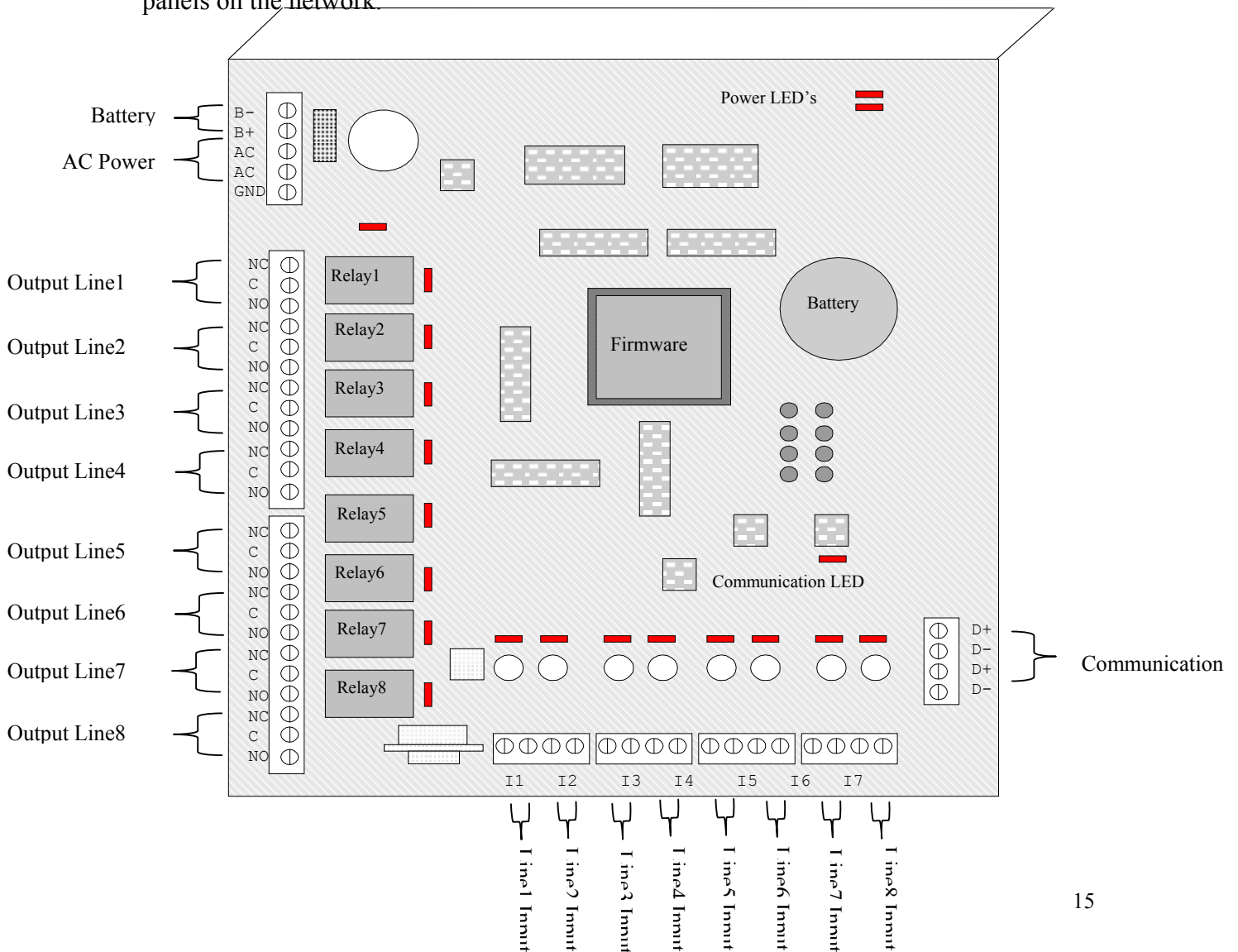

Elevator Controller Specifications

- 8 Floor control
- With Or without button sensing
- Battery back up Circuitry
- On board firmware clock
- Supports Wiegand 26 bit format (other on special request)
- 65,000 user on board storage
- 2000 event on board storage
- Power Requirements: 16.5VAC @ 40VA transformer
- Option Stand By battery 12VDC 7.0Ah
- Relays are Form C contact rated at 10A 125VAC
- On board LED to indicate communications, Active Relays, AC source, as well as state of inputs.

The Elevator Controller is a stand-alone unit similar to our door controllers. Each Panel has a unique address indicated on PLCC chip in center of board. If button sensing is disabled when a valid card is presented all relays that card is good for will be thrown for the programmed time. If button sensing is enabled when a valid card is presented the system will wait for a button to be pressed (for programmed time) then if cardholder is valid for that floor the respective relay will be thrown for the programmed time.

Elevator Controller Layout

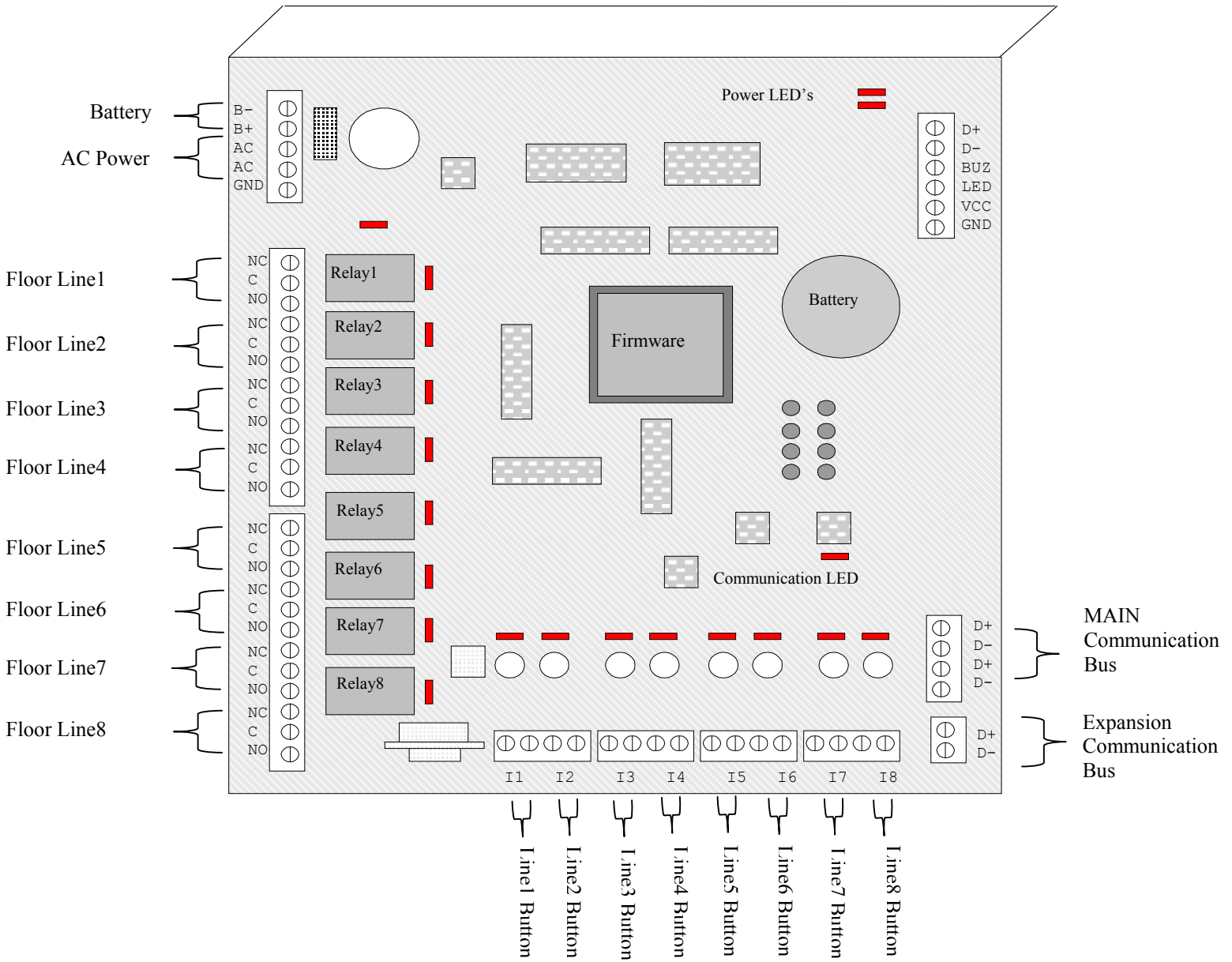

Elevator Expansion Module Connection

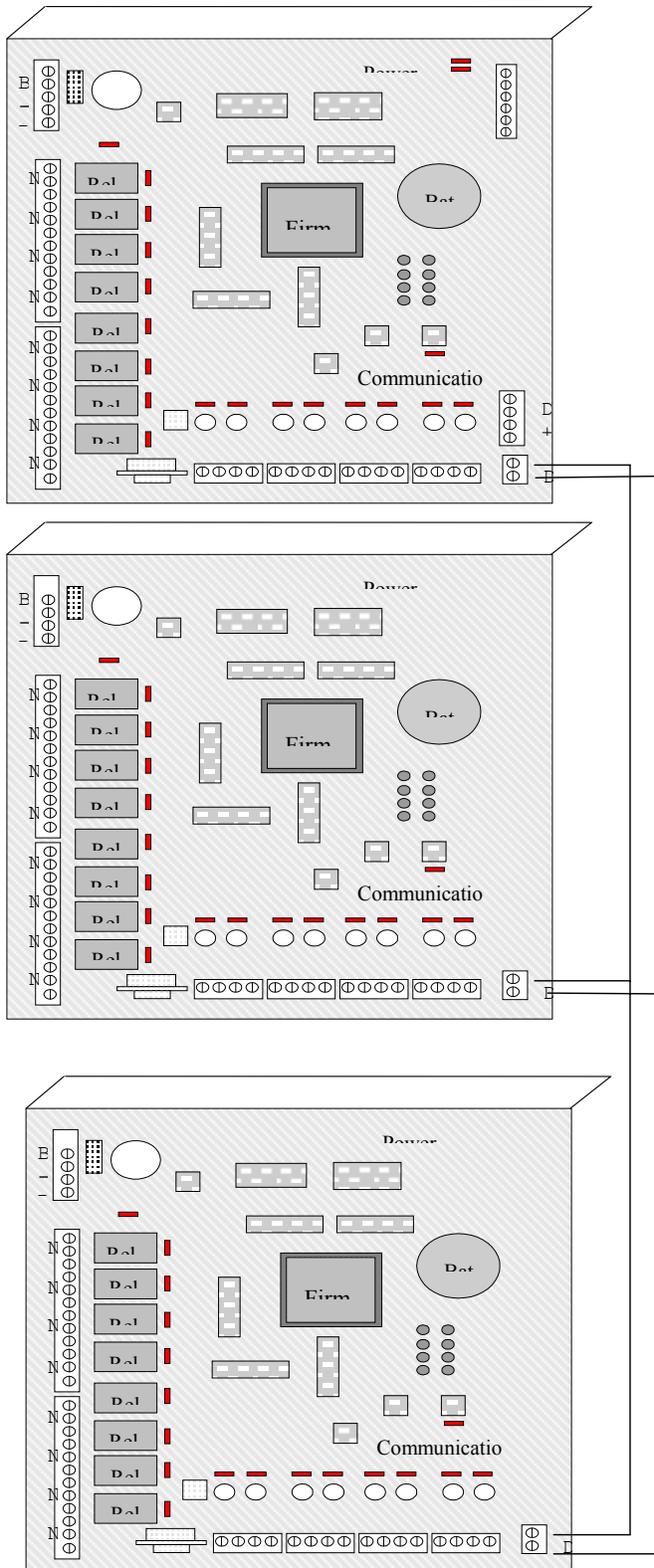

Expansion Modules Are Connected Daisy Chain D+ to D+ and D- to D-.

First Expansion module should be labeled EX1. It will correspond to floors 9 – 17.

Second Expansion module should be labeled EX2. It will correspond to floors 18 – 24.

And So On.

Dial Up Modem Configuration

We tested various modems, which resulted in the following specification.

Field Modem: U.S.Robotics External Fax Modem V.92 (Mod - 5686E)

P.C. Modem: U.S.Robotics External Fax Modem V.92 (Mod - 5686E) or
U.S.Robotics Internal Fax Modem (ISA/PCI Hardware
Modem Not Win Modem)

Field Modem Configuration

Modem Type: U.S.Robotics External Fax Modem V.92 (Mod - 5686E)

Recommended Initialization String:

ATF1S0=1&A&B&H&I&K&M&N10&R1&Y0&W0

- Note: Panels Communicate at 19,200 bps, 8Data bits, No Parity, 1Stop Bit, No Flow Control.

It is very important that:

- Error Detection is turned off.
- All Handshaking is disabled.
- Hardware and Software Flow Control is disabled
- DTR Line is ignored.
- Auto Answer is turned on.
- All Echoing is turned off.
- Port Serial setting is set for 19,200 bps

Dip Switch Settings

- | | |
|--------------|---|
| 1 ON | Data Terminal Ready (DTR) Override. |
| 2 OFF | Verbal/Numeric Result Codes. |
| 3 ON | Result Code Display. |
| 4 OFF | Command Mode Local Echo Suppression. |
| 5 OFF | Auto Answer Suppression. |
| 6 OFF | Carrier Detect (CD) Override. |
| 7 OFF | Power-on and ATZ Reset Software Defaults. |
| 8 ON | AT Command Set Recognition. |

Field Modem wiring

Serial Cable for Modem device:

Male DB9 >>>>>>>>>> Male DB25

Pin 2 >>>>>>>>>> Pin 2

Pin 3 >>>>>>>>>> Pin 3

Pin 5 >>>>>>>>>> Pin 7

PC Modem Configuration

We tested with several internal Modems. All worked with some tweaking to the initialization string.

Our testing found the following U.S.Robotics External Modem to be the best performer.

Modem Type: U.S.Robotics External Fax Modem V.92 (Mod - 5686E)

Recommended Initialization String:

AT&F1E0F1S0=0&A&B0&H&K&I&M&R1&N10&U10&W0

Dip Switch Settings

- 1 OFF** Data Terminal Ready (DTR) Override.
- 2 OFF** Verbal/Numeric Result Codes.
- 3 ON** Result Code Display.
- 4 OFF** Command Mode Local Echo Suppression.
- 5 OFF** Auto Answer Suppression.
- 6 OFF** Carrier Detect (CD) Override.
- 7 OFF** Power-on and ATZ Reset Software Defaults.
- 8 ON** AT Command Set Recognition.

U.S.Robotics Internal Fax Modem (ISA Hardware Modem - Not Win Modem)

Recommended Initialization String:

ATE0F1S0=0&A&B0&H&K&I&M&R1&N10&W0

If you chose to try an alternative modem using your own In house support you can try the following Initialization string as a starting point as this worked for us with tested Generic Win Modems.

AT&Q1E0S0=1K&M&R1&DW0

Using Protector Dial-Up Software

Please be patient when using the software, i.e. after issuing a command such as connect to remote site do not follow up with a disconnect command right after. Allow the system to go through with each command before issuing the next. All commands are queued and since dial up is inherently a slower process you could end up with several commands queued in the system delaying your current requests.

TcpIp Configuration using Lantronix UDS-10

Although you can use any TcpIp serial server, all of our testing is done using the Lantronix UDS-10 system.

Please note it is your responsibility to set up TCP/IP service so that UDS-10 is found on the network.

Note: Panels Communicate at 19,200 bps, 8Data bits, No Parity, 1Stop Bit, No Flow Control.

UDS-10 Configuration for direct RS485 to Field panels.

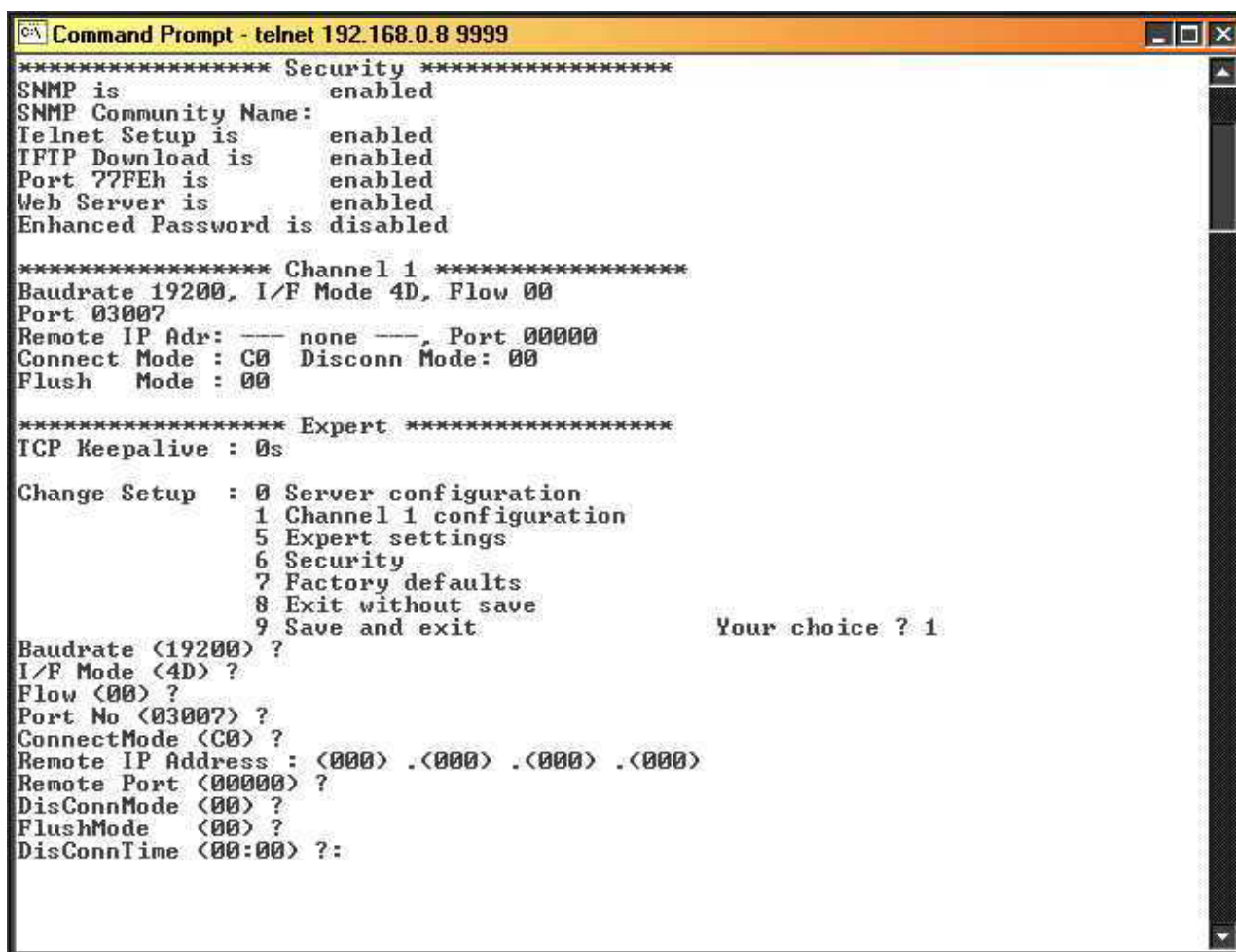
A screenshot of a telnet session window titled "Command Prompt - telnet 192.168.0.8 9999". The window displays a menu of configuration options for the UDS-10 system. The options are grouped into sections: Security, Channel 1, and Expert. The Security section lists: SNMP is enabled, SNMP Community Name, Telnet Setup is enabled, TFTP Download is enabled, Port 77FEh is enabled, Web Server is enabled, and Enhanced Password is disabled. The Channel 1 section lists: Baudrate 19200, I/F Mode 4D, Flow 00, Port 03007, Remote IP Addr: --- none ---, Port 00000, Connect Mode: C0, Disconn Mode: 00, and Flush Mode: 00. The Expert section lists: TCP Keepalive: 0s. Below these sections is a "Change Setup" menu with options: 0 Server configuration, 1 Channel 1 configuration, 5 Expert settings, 6 Security, 7 Factory defaults, 8 Exit without save, and 9 Save and exit. The prompt "Your choice ? 1" is displayed. At the bottom, there are several configuration parameters with their current values and prompts for change: Baudrate (19200) ?, I/F Mode (4D) ?, Flow (00) ?, Port No (03007) ?, ConnectMode (C0) ?, Remote IP Address : (000) .(000) .(000) .(000) ?, Remote Port (00000) ?, DisConnMode (00) ?, FlushMode (00) ?, and DisConnTime (00:00) ?:.

UDS-10 RS485 Wiring

Please keep shield connected for full run of cable. Leave both ends floating.

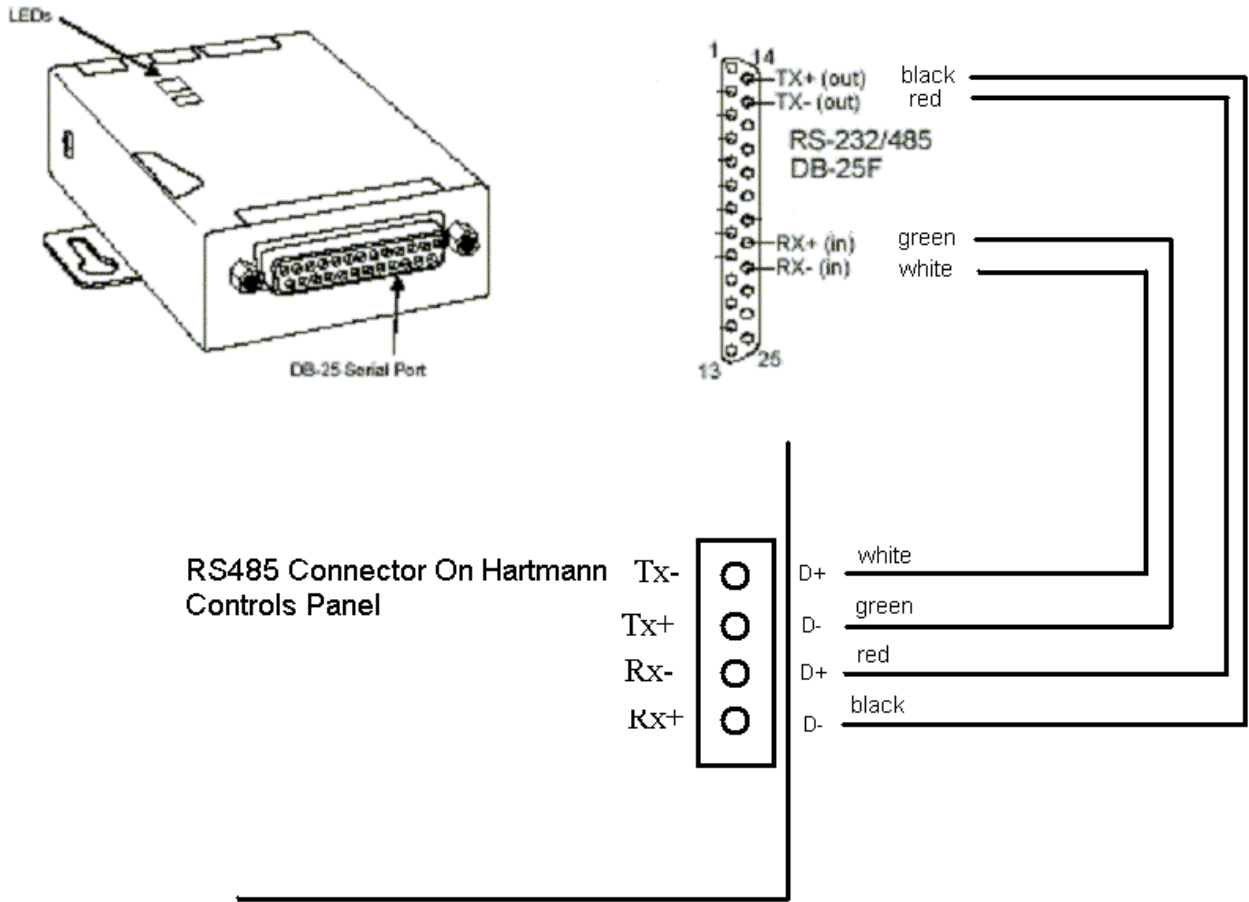

EverSwitch Keypad Wiring Diagram

