

HCT Ultimate, gear reduced, high traffic operator

5 Year Warranty

Applications:

The Model HCT gear-reduced high-traffic operator is designed for parking garages, apartment houses and high-cycle standard lift sectional overhead door applications.

Standard Features:

- OmniControl™ board (O) – the OmniControl™ board uses LEDS to indicate all input and output functions of the operator; also available are easy to install, modular plug loop detectors
- On-board 3-button control station for ease of installation
- Omni extension board required to operate external 3-button control station, both sold separately
- 312HM universal coaxial receiver with Security+® standard
- Ultra-low-profile design – only 8" high
- High-starting torque continuous-duty C-faced 1/2 HP 115V motor with digital overload protection
- Heavy-duty wormgear-in-oil-bath speed reducer with 40:1 reduction
- Heavy-duty noise isolators on chassis to prevent noise and vibration
- UMHV front end idler for durability and quiet operation
- Emergency disconnect with key release for manual operation
- Motor removable without affecting limit setting
- NEMA 1 electrical enclosure
- Reversing sensor – the two-way reversing sensor and the alarm system are standard features
- Inputs for radio receiver, key switch, telephone entry system
- Adjustable timer standard can be set from 3 to 60 seconds
- Convenient on/off switch controls power to the board (located in the unit).
- #41 chain standard for increased performance and durability
- Door speed approximately 8-12 inches per second
- Shipping Weight
HCT8 165 lbs
HCT10 188 lbs
HCT12 193 lbs



MAXIMUM DOOR AREA (SQ. FT.)				
STANDARD SECTIONAL	24 ga. Steel	20 ga. Steel	18 ga. Steel	—
	Alum. Doors	Wood Doors	—	—
	Fiber-glass Doors	24 ga. Steel Insul.	20 ga. Steel Insul.	16 ga. Steel Insul.
SQ. FT.	250	225	150	100

NOTE: On steel insulated doors, a 24 ga. back panel is assumed.

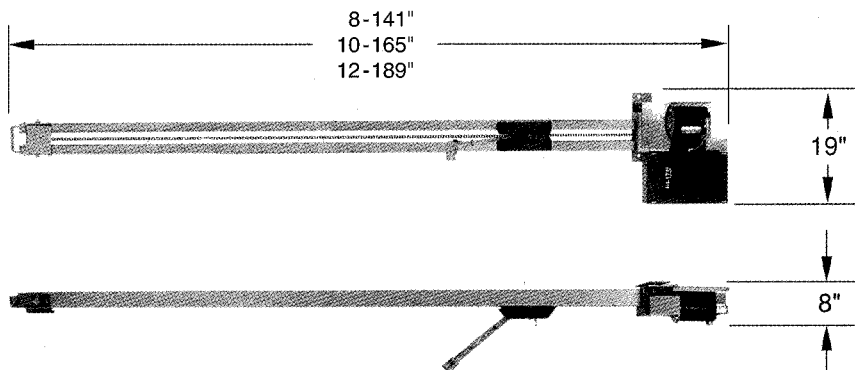

OPERATOR AMP RATING (Full Load)			
		HP	1/2
VOLTAGE - PHASE	60 HZ	115-1Ø	4.1

